

Doc. 573.472.050 Date/Datum/Fecha : 01/06/15 Annule/Cancel/ Ersetzt/Anula :	Modif. / Änderung :	Pièces de rechange Spare parts list Ersatzteilliste Piezas de repuesto
---	----------------------------	---

POMPE, modèle EOS 03R440	PUMP, model EOS 03R440
PUMPE, Modell EOS 03R440	BOMBA, tipo EOS 03R440

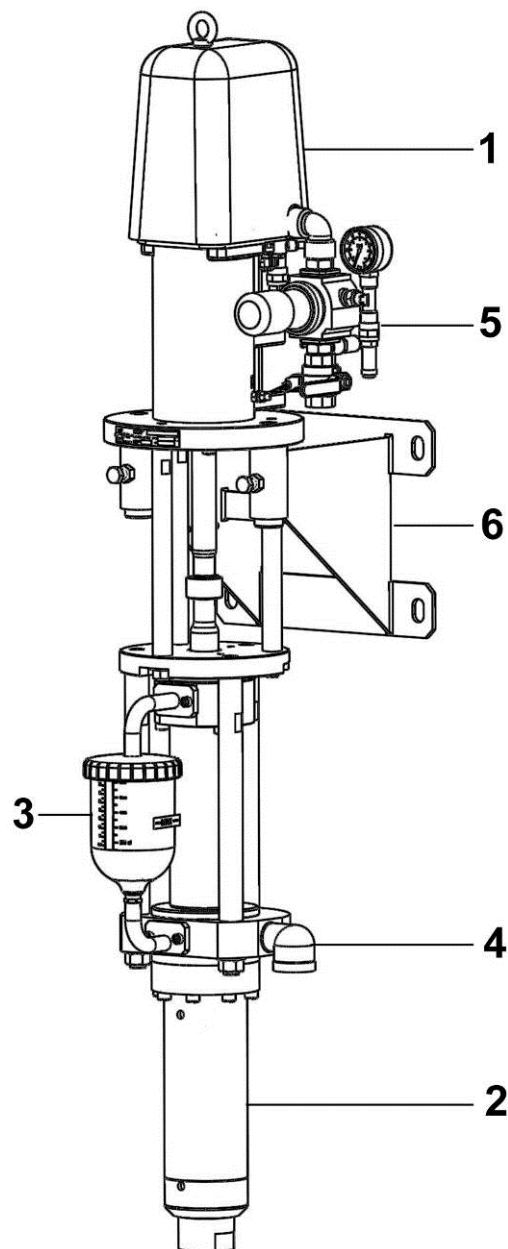

POMPE MURALE, modèle EOS 03R440 (Pour produit solvanté)	WALL MOUNTED PUMP, model EOS 03R440 (For solvent product)	#
WANDANLAGE, Modell EOS 03R440 (Für Lösemittel Materialien)	BOMBA MURAL, tipo EOS 03R440 (Para producto disolventado)	151.866.100

POMPE MURALE, modèle EOS 03R440 (Pour produit hydro)	WALL MOUNTED PUMP, model EOS 03R440 (For hydro material)	#
WANDANLAGE, Modell EOS 03R440 (Für Wasser Materialien)	BOMBA MURAL, tipo EOS 03R440 (Para producto hidro)	151.866.300

Pièces communes - Common parts - Gleiche Teile - Partes comunes

Ind	#	Désignation	Description	Bezeichnung	Denominación	Qté
-	NC / NS	Pompe EOS 03R440 nue	Bare pump, model EOS 03R440	Pumpe Modell EOS 03R440	Bomba sola, tipo EOS 03R440	1
*1	146 305 200	▪ Moteur 1500-100 (voir Doc. 573.473.050)	▪ Motor, model 1500-100 (refer to Doc. 573.473.050)	▪ Motor, 1500-100 (siehe Dok. 573.473.050)	▪ Motor, tipo 1500-100 (consultar Doc. 573.473.050)	1
*3	144 990 530	▪ Godet équipé (voir Doc. 573.465.050)	▪ Cup assembly (refer to Doc. 573.465.050)	▪ Kompletter Behälter (siehe Dok. 573.465.050)	▪ Bote equipado (consultar Doc. 573.465.050)	1
-	906 314 219	Bouchon 1"	Plug, model 1"	Stopfen, 1"	Tapón, tipo 1"	1
4	905 210 404	Coude MF 1"	Elbow, model MF 1"	Winkelnippel, AG/IG 1"	Codo, tipo MH 1"	1
5	016 480 000	Détendeur d'air 3/4 0 - 10 bar - volant rouge	Air regulator, model 3/4 0 - 10 bar / 0 - 145.1 psi - red knob	Druckminderer, 3/4 0 - 10 bar (Rote Stellglocke)	Manorreductor de aire, tipo 3/4 0 - 10 bar - pomo rojo	1
6	9 015	Support de pompe	Pump bracket	Wandhalterung	Soporte de bomba	1

Pièces spécifiques - Specific parts - Spezifische Teile - Partes específicas

pour produit solvanté / for solvent material / für Lösemittel Materialien / para producto disolventado

Ind	#	Désignation	Description	Bezeichnung	Denominación	Qté
*2	144 990 500	▪ Hydraulique R 440 (voir Doc. 573.462.050)	▪ Fluid section, model R 440 (refer to Doc. 573.462.050)	▪ Hydraulikteil R 440 (siehe Dok. 573.462.050)	▪ Hidráulica, tipo R 440 (consultar Doc. 573.462.050)	1

Pièces spécifiques - Specific parts - Spezifische Teile - Partes específicas

pour produit hydro / for hydro material / für Wasser Materialien / para producto hidro

Ind	#	Désignation	Description	Bezeichnung	Denominación	Qté
*2	144 990 600	▪ Hydraulique R 440 (voir Doc. 573.462.050)	▪ Fluid section, model R 440 (refer to Doc. 573.462.050)	▪ Hydraulikteil R 440 (siehe Dok. 573.462.050)	▪ Hidráulica, tipo R 440 (consultar Doc. 573.462.050)	1

- * Pièces de maintenance préconisées
- * Preceding the index number denotes a suggested spare part.
- * Bezeichnete Teile sind empfohlene Ersatzteile.
- * Piezas de mantenimiento preventivas.

- N C : Non commercialisé.
- N S : Denotes parts are not serviceable.
- N S : Bezeichnete Teile gibt es nicht einzeln, sondern nur komplett.
- N S : no suministrado.