

PUMP EOS 06-R440

Disassembly / Reassembly

TRANSLATION FROM THE ORIGINAL MANUAL

IMPORTANT : Before assembly and start-up, please read and clearly understand all the documents relating to this equipment (professional use only).

THE PICTURES AND DRAWINGS ARE NON CONTRACTUAL. WE RESERVE THE RIGHT TO MAKE CHANGES WITHOUT PRIOR NOTICE.

KREMLIN - REXSON

150, avenue de Stalingrad

93 245 - STAINS CEDEX - France

☎ : 33 (0)1 49 40 25 25 Fax : 33 (0)1 48 26 07 16

www.kremlin-rexson.com



CAUTION :

Before any action on the pump, the T lubricant should be removed, shut off the compressed air supply and depressurize the system.

The pump is manufactured under the ATEX agreement and can not be modified. KREMLIN REXSON will not be held responsible for any failure to comply with that instruction.

▪ **FLUID MOTOR OR AIR MOTOR REPLACEMENT (REFER TO DOC. 573.462.050 & 573.463.050)**

Guards (air motor cover, coupling shields, housings ...) have been designed for safe use of the equipment.

The manufacturer will not be held responsible for bodily injury or failure and / or damage to property due to removal or partial removal of the guards

To work on the pump, it requires to :

- Disassemble all the accessories of the pump (rod, filter), if necessary.
- The T lubricant should be removed from the upper part (A).
- Put aside the pump, if necessary (the pump is fitted with an hoisting ring).

The pump fluid section is made up of 2 sub-assemblies :

- the upper part (bellows suction sub-assembly : A)

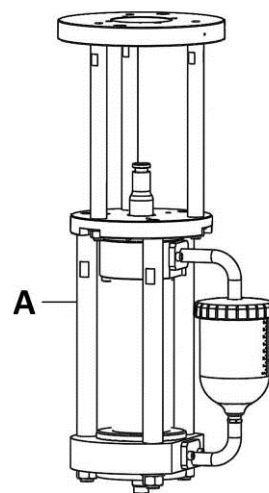

- the lower part (fluid sub-assembly: B)



The most frequently maintenance concerns this part.

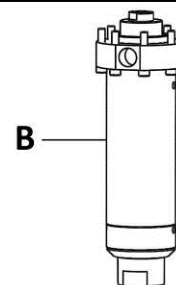

PUMP DRAINING

**Guards (air motor cover, coupling shields, housings ...) have been designed for safe use of the equipment.
The manufacturer will not be held responsible for bodily injury or failure and / or damage to property due to removal or partial removal of the guards**

Place a container (2L / 0.53 US gal minimum) under the drain plug.

Unscrew the drain plug with a hexagon key size 12mm.

A procedure must be applied for the safe disposal of waste material. It must comply with all prevailing regulations and legislations of the country where the equipment is to be used

REPLACING THE PLUG

Clean the drain plug.



Apply a light coating of glue to the drain plug threading (Loctite 577)

Screw the drain plug with a hexagon key size 12mm.

PUMP SEPARATION / COUPLING PROCEDURE

Guards (air motor cover, coupling shields, housings ...) have been designed for safe use of the equipment.
The manufacturer will not be held responsible for bodily injury or failure and / or damage to property due to removal or partial removal of the guards

SEPARATE THE PUMP

- Stop the pump.
- Lift the axis-lock (37).
- Lift the closing ring (19).
- Take off the bush (38) and the closing ring (19).
- Unscrew the nuts (5) from the coupling tie-rods.

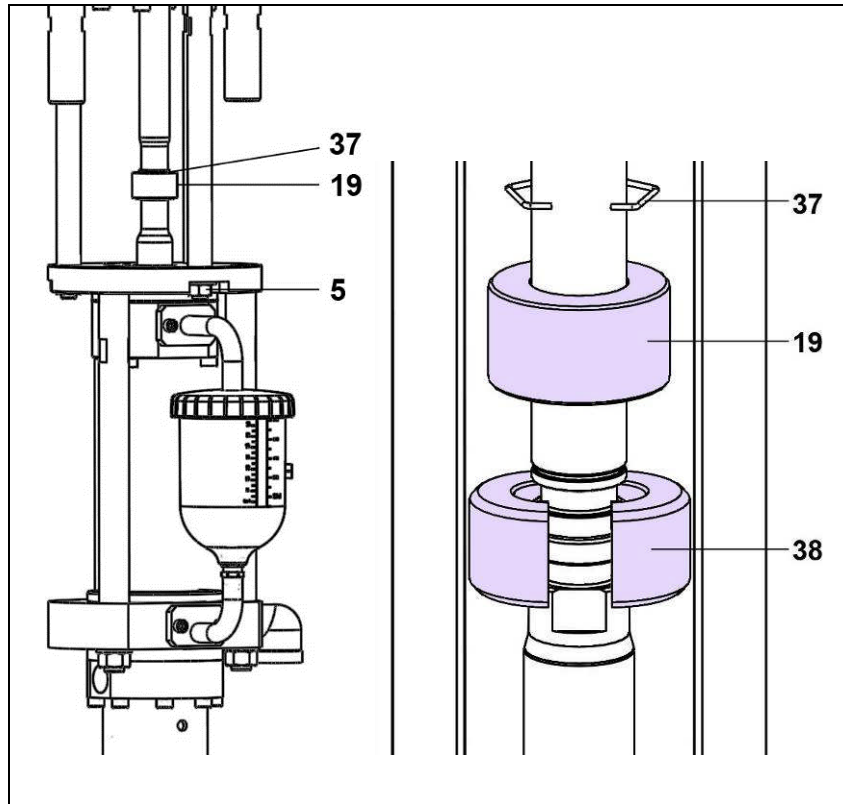

COUPLING THE PUMP

- Unscrew the nuts (5) from the coupling tie-rods.
- After sliding the axis-lock (37) and the closing ring (19), take off the motor piston rod to bring in contact with the pump piston.
- Put the bush (38) on motor and pump piston rod ends.
- Go down the closing ring (19).
- Put the axis-lock (37).

FILLING THE SUCTION SUB-ASSEMBLY (A) WITH T LUBRICANT

Nota : Use only lubricant compatible with the parts in contact with the product (See data sheet of the product manufacturer).

Use only KREMLIN REXSON T lubricant.

- Unscrew the lid from the cup (3).
- Run the pump to load the product.
- When the pump is loaded fill the T lubricant into the cup (1) until it reaches the maximum level.
- Refill with the T lubricant until the backflow into the cup ($\approx 1.2L / 0.32$ US gal).
- Screw the lid on the cup (3).

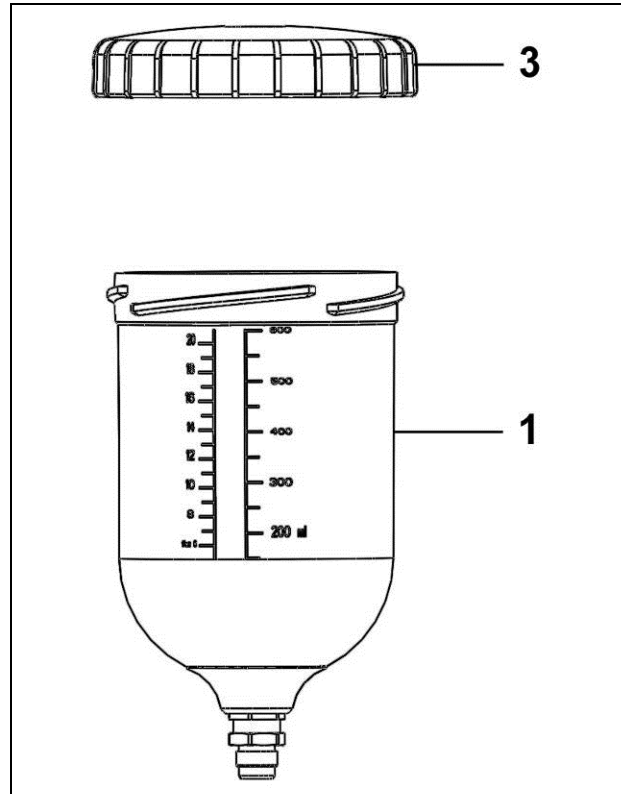

DISASSEMBLY / REASSEMBLY OF THE FLUID SECTION

Guards (air motor cover, coupling shields, housings ...) have been designed for safe use of the equipment.
The manufacturer will not be held responsible for bodily injury or failure and / or damage to property due to removal or partial removal of the guards

DISASSEMBLY / REASSEMBLY OF THE FLUID SUB-ASSEMBLY (B)

Nota : The suction valve, the cylinder, the exhaust valve can be removed or change without needing to separate the product sub-assembly (B) from the suction sub-assembly (A).

■ SUCTION VALVE (34)

Disassembly

Unscrew the suction valve (34) with a 50mm wrench.

Nota : If the cylinder (32) remains attached to the suction valve, unscrew both parts, then hold cylinder (32) by inserting a rod into the cylinder holes designed for this purpose.

The ball (37) is secured on the valve (35) by means of a stop ring (36).

Clean the parts with an appropriate cleaning product.

Assembly

Reinstall the ball (37) and the stop ring (36) on the suction valve body (35).

Change the seal (28). Grease it.

 Apply grease to the suction valve body thread .

Remount the valve assembly (34) on the cylinder (32).

■ CYLINDER (32)

In order to make easier the disassembly, a hole is drilled in the cylinder (32) at each end.

Depending on the part that it is unscrewed first, insert a rod into one of these holes to unscrew the other part.

When reassembling, make sure the two seals (28) are installed. Grease them.

 Lubricate inside the cylinder (grease, type A1) and the threads to prevent damaging the mobile packing (grease, type A2) - (refer to greases in § Assembly instructions).

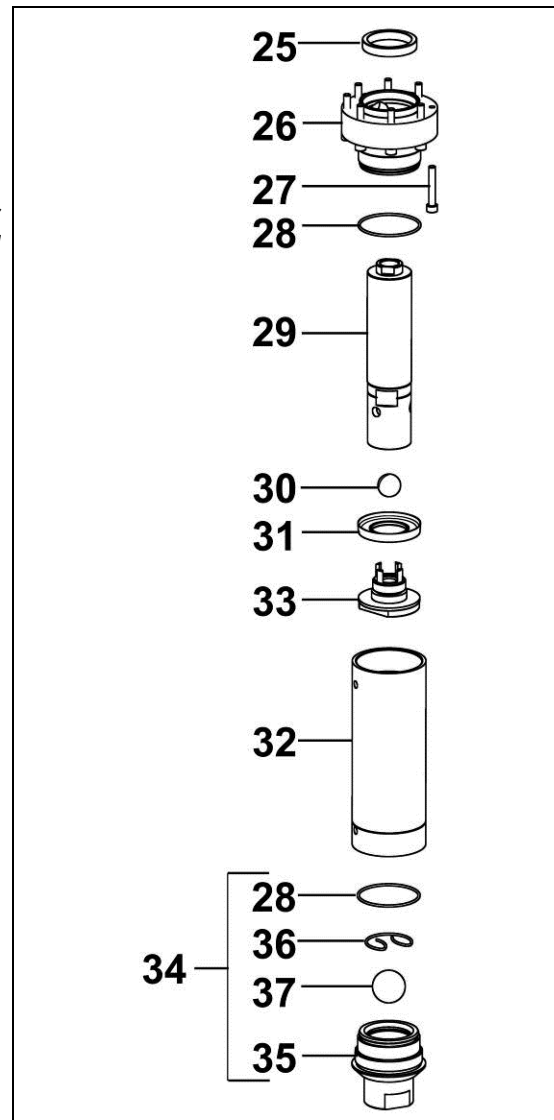

▪ **EXHAUST VALVE (33) AND CUP SEAL (31)**

Disassembly

Unscrew the cylinder (32) and pull it downwards..

Unscrew the exhaust valve (33) with a 58mm wrench by holding the piston (29).

Remove the ball (30),

Remove the cup seal (31).

Clean the parts.

Assembly

Remount a new cup seal (31),

Reinstall the ball (30) on the exhaust valve (33).

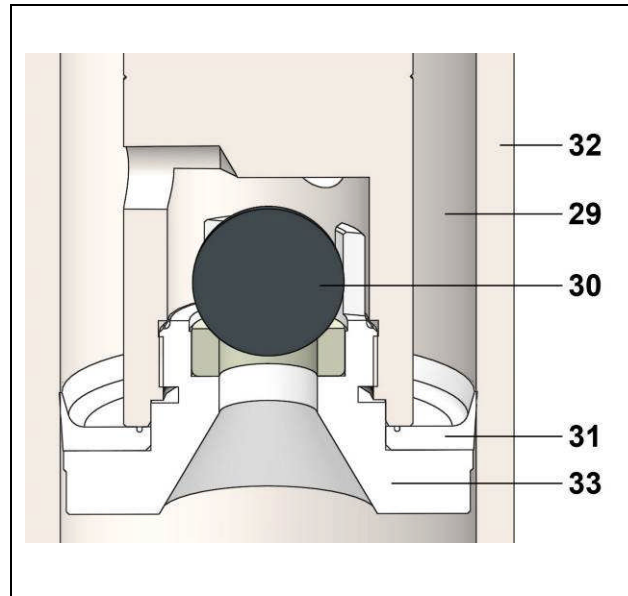

⚠ Apply a light coating of grease to the threading of exhaust valve (33) (grease, type A2).
Screw the part in the piston lower part (29) (refer to greases in § Assembly instructions).

DISASSEMBLY / REASSEMBLY OF THE SUCTION SECTION SUB-ASSEMBLY (A)

Nota : The disassembling of the upper tightness seal and of the bellows requires to separate the fluid sub-assembly (B) from the suction sub-assembly (A).

SEPARATION PROCEDURE

Disassemble the cylinder (32). You can see the fluid section (29).

➤ You must place the piston downwards.

⚠ Install an air pressure (from 0.2 to 0.5 bar / from 2.9 to 7.2 psi) on the air motor. When the piston is at its lower point, close the air inlet valve to prevent the piston from getting up.

Remove the 3 nuts (22), the washers (21).

Pull the suction flange (20) downwards, you can see the skirt (10).

Nota: The cylinder (17) must keep assemble with the suction bearing (11).

Unscrew slightly 3 screws (15).

Unscrew the skirt (10) (tools : with a 36mm wrench).

Nota : To make easier the disassembly of the skirt, you can remove one of the 3 pump tie-rods (19).

Slide up the skirt-bellows set to clear the access to the flat on the coupling rod (8).

⚠ Caution : the skirt must be visible.

By means of 2 wrenches, to separate the piston (29) from the coupling rod (8) by using the flats on the coupling rod and those on the base of the piston.

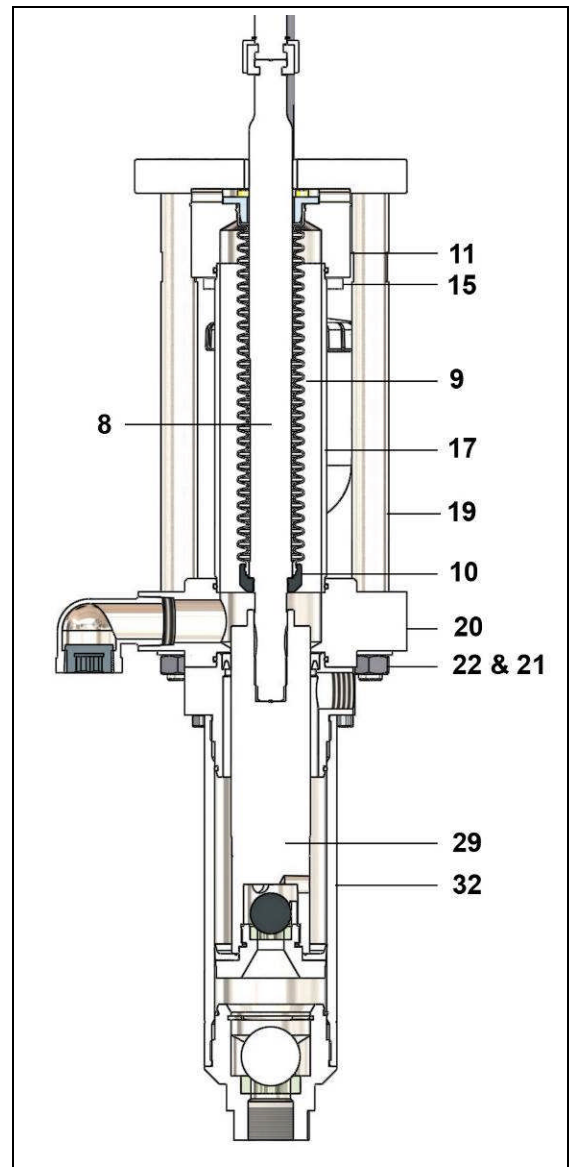

COUPLING PROCEDURE

 Change all the seals (16 and 28) and lubricate them.

Clean the threading of the coupling rod (8) and the tapping of the pump piston (29).

Slide down the motor rod (see previous §) .

 **Apply a light coating of glue to the threading of the motor rod (Loctite 222).**

Present piston-fluid section-discharge flange assembly

Screw the motor rod into the fluid section piston. Lock the assembly.

 **Apply a light coating of glue to the fluid section piston threading (Loctite 577).**

➤ **Pull the skirt (10) downwards, and screw it onto the fluid section piston (29).**
(tool : with a 36mm wrench).

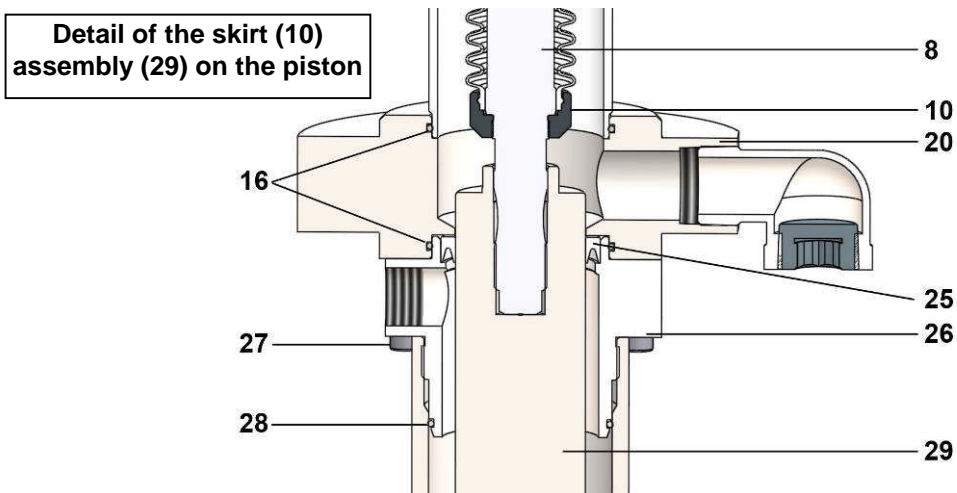

Remount the coupling rod (19) if it has been removed.

Replace the suction flange (20).

Screw the 3 screws (15).

Reinstall the 3 washers (21) and screw the nuts (22).

Remount the pump lower part as explained previously (cylinder, suction,...).

■ UPPER TIGHTNESS SEAL (25)

Disassembly

Unscrew the 8 screws (27).

Separate the fluid section (A) from the suction part (B).

Remove the GT seal (25) by pulling the exhaust flange (26) downwards.

Remove the O-ring seals (16 and 28).

Assembly

 Place a new GT seal (25) into the discharge flange (26) after having lubricated it.

➤ **Comply with the GT seal (25) installation order.**

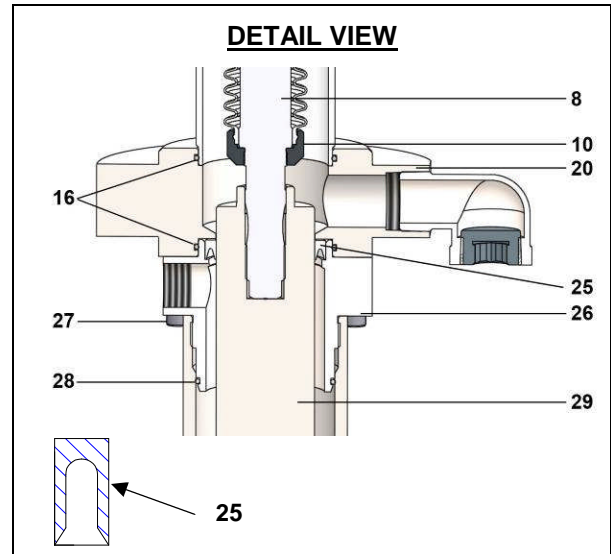

■ BELLOWS

This operation must be done after the separation of the lower part from the upper part of the fluid section and after the dismounting of the upper tightness seal.

In the work table, prepare assembly, which consists of fluid section piston-exhaust flange while following the procedure of the upper tightness seal (25).

Disassembly

- Remove the cylinder (17) from the suction bearing (11).
- Separate the suction bearing (11) from the motor by removing the screws (15).
- Slide, then put aside the bellows-skirt-flange assembly.
- Remove the bellows flange (7) to take off the upper part of the bellows.
- Dismount the skirt (10).

Assembly

On the work table, prepare a bellows-skirt-flange set. You must :

- Install a new bellows (9) into the bellows flange (7).
- When installing the bellows, push it into skirt (10).
- Install the upper bellows flange (7).
- Slide the bellows-skirt-flange assembly along the motor rod.

Orientate and tighten it on air motor base by means of the 3 screws (15).

Nota : To make easier the reassembly, you can remove one of the three tie rods (19).

Couple product section (B) with the suction part (A).

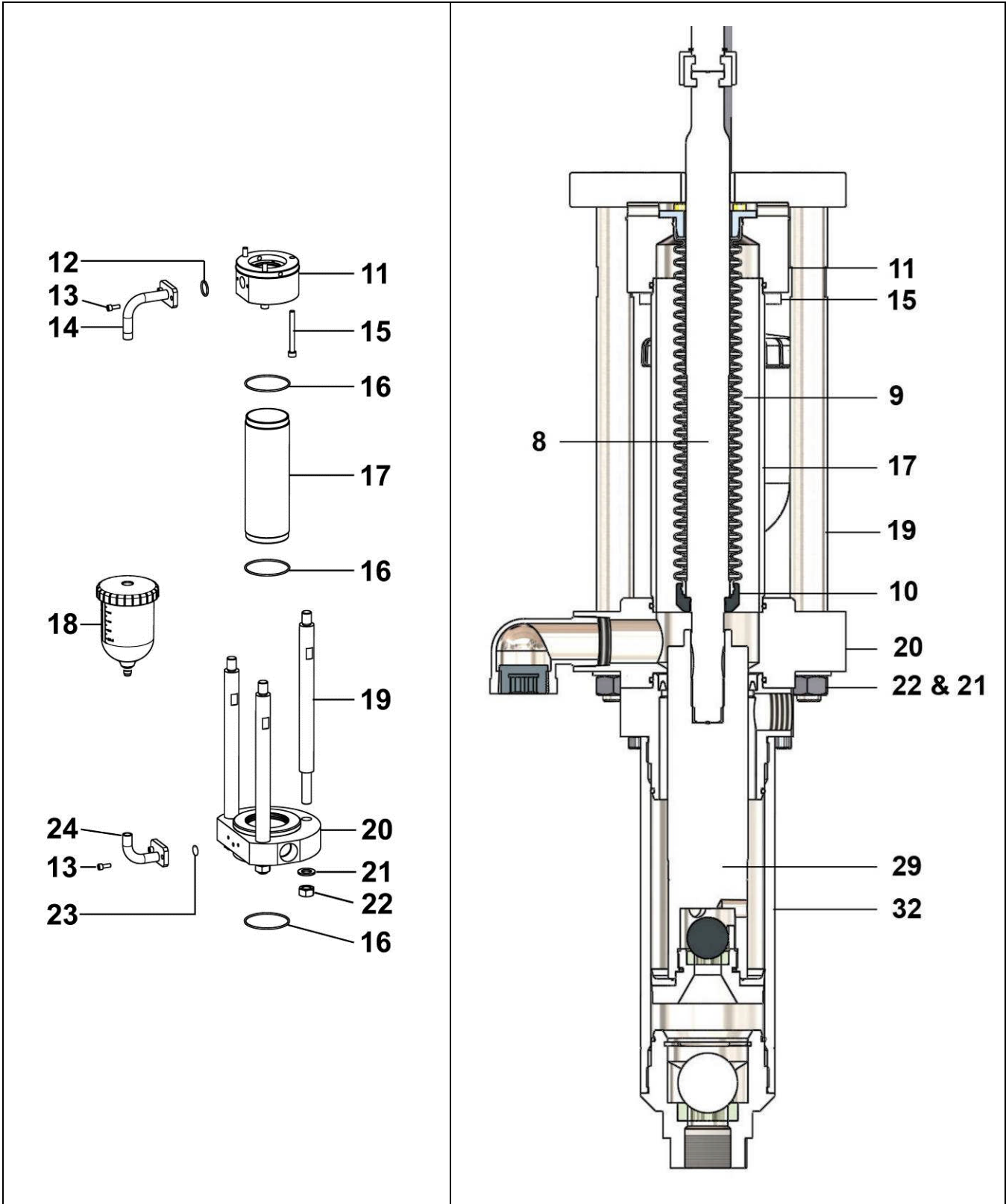

▪ CUP

Disassembly

- Unscrew the lid (3) from the cup (1).
- Unscrew the cup (18) from the elbow tube (24) with a 17mm wrench.
- Remove the lid (3) from the elbow tube (24).
- Separate by hand the end cup (9) and remove the assembly (5, 9, 7 and 2) from the cup.
- Remove the screen (2).
- Unscrew the nut (7) with a 8mm wrench and the washer (8) from the valve (5).
- Unscrew the valve body (4) with a 18mm wrench from the upper elbow tube (14).
- Unscrew the nut (7) with a 8mm wrench and the washer (8) from the valve body (4) and remove the spring (6) with its washer (8).

Assembly

- Slide the lid of the cup onto the upper elbow tube (14) and hold it in the up position.
- Screw the upper valve assembly with the valve (5), the spring (6), the washer (8), the nut (7) with a 8mm wrench and the washer (8) onto the valve body (4).
- Screw the upper valve onto the elbow tube (14) with a 18mm wrench.
- Screw the lower valve with the valve (5) and the nut (7) with a 8mm wrench onto the end cup (9).
- Place the screen (2).
- Clip manually as far as it will go the lower valve assembly into the cup.

⚠ Apply a light coating of glue to the cup threading (Loctite 577).

- Screw the reassembled cup (1) onto the lower elbow tube (24).
- Screw the lid (3) onto the cup (1).

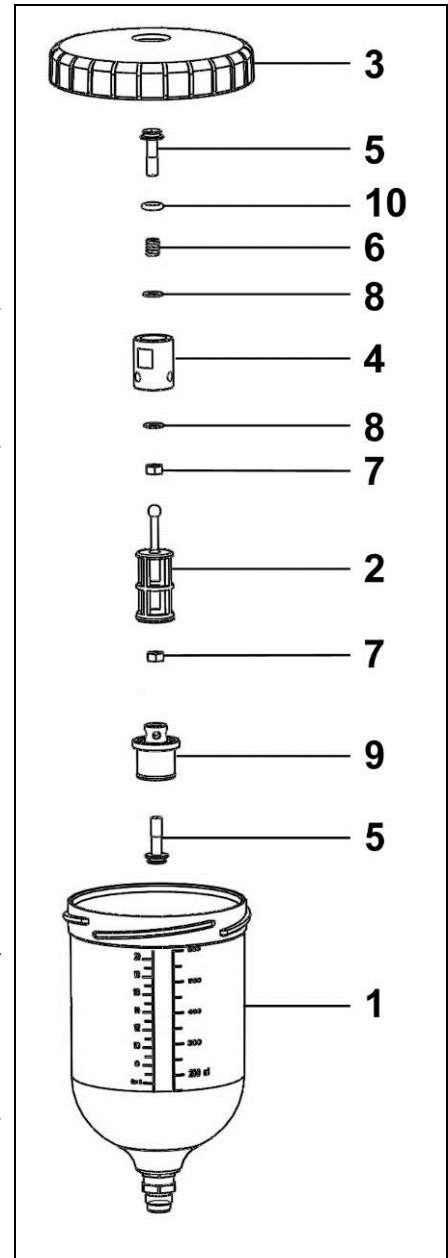

MOTOR

▪ REVERSING BLOCK

Guards (air motor cover, coupling shields, housings ...) have been designed for safe use of the equipment.
The manufacturer will not be held responsible for bodily injury or failure and / or damage to property due to removal or partial removal of the guards

The maintenance consists in changing the wetted or worn parts and to clean the parts with compatible materials without using abrasive materials that can damage them. The O-Rings are installed with "Kluber petamo" grease. Make sure the seals are not damaged, one damaged seal can lead to a motor malfunction.

▪ MUFLER

Disassembly

- Unscrew the muffler (15)

Assembly

- Screw the muffler (15).

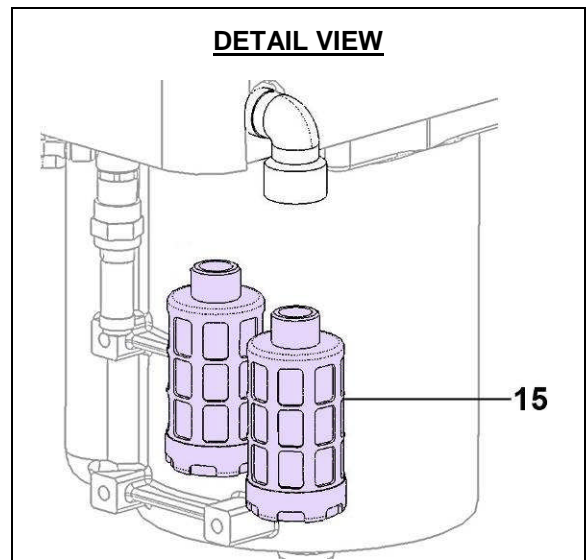

DISCHARGE VALVE

Disassembly

- Unscrew the discharge-valve (14).

Assembly

⚠ Apply a light coating of glue to the discharge valve threading (Loctite 222).

- Screw the discharge valve (14).

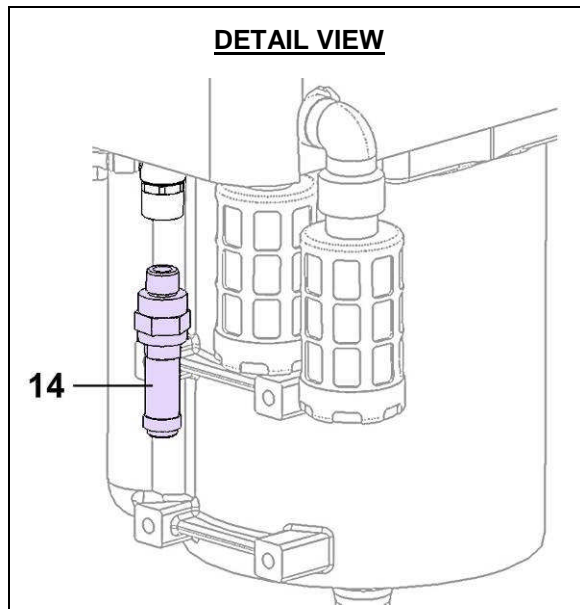

DISTRIBUTOR, MODEL 4/2

Disassembly

- Unscrew the hoisting ring (1) and remove the washer (2).
- Remove the cover (3).
- Unscrew the 4 screws (19) with a hexagon key size 4mm.
- Remove the distributor (10).

Assembly

- Replace the distributor (10) on its location.
- Screw the 4 screws (19) with a hexagon key size 4mm.
- Replace the cover (3).
- Put the washer (2).
- Screw the hoisting ring (1).

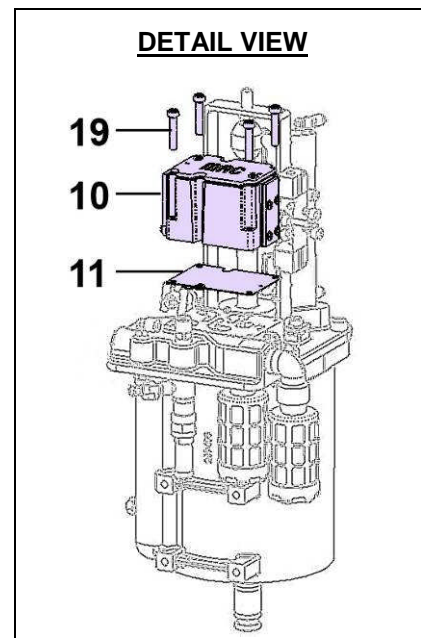

▪ **DISTRIBUTOR, MODEL 5/2 1/8"**

Disassembly

- Unscrew the hoisting ring (1) and remove the washer (2).
- Remove the cover (3).
- Disconnect the hoses (42).
- Unscrew the 2 screws (56) with a hexagon key size 2,5mm.
- Unscrew the 5 elbows (45) with a 10mm wrench.

Assembly

⚠ Apply a light coating of glue to the elbow threading (Loctite 222).

- Screw the 5 elbows (45) with a 10mm wrench.
- Screw the 2 screws (56) with a hexagon key size 2,5mm.
- Connect the hoses (42).
- Replace the cover (3).
- Put the washer (2).
- Screw the hoisting ring (1).

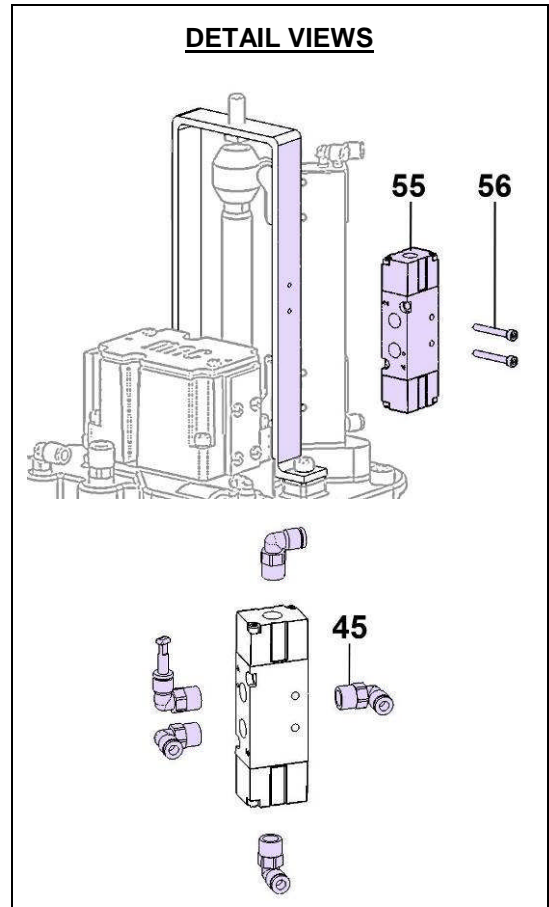

▪ **SWITCH**

Disassembly

- Unscrew the hoisting ring (1) and remove the washer (2).
- Remove the cover (3).
- Identify and disconnect the hoses (42).
- Unscrew the 4 screws (53) with a hexagon key size 3mm.

Assembly

- Screw the 4 screws (53) with a hexagon key size 3mm.
- Connect the hoses (42).
- Replace the cover (3).
- Put the washer (2).
- Screw the hoisting ring (1).

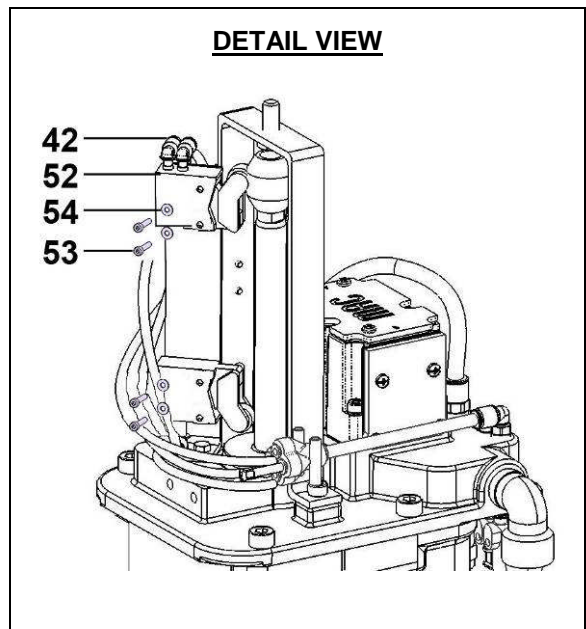

SEALS

First remove, the axis-lock, the closing ring, the bush used for the pump separation.

Disassembly

- Unscrew the hoisting ring (1) and remove the washer (2).
- Remove the cover (3).
- Identify and disconnect the hoses (42).
- Remove the elbows (41).
- Unscrew the 2 screws (5) with a hexagon key size 5mm and remove the u-bolt (4).
- Unscrew the 4 screws (53) with a hexagon key size 3mm.
- Unscrew the screw (7) with a hexagon key size 4mm and remove the cam (8).
- Unscrew the 4 screws (23) with a hexagon key size 6mm and remove the cover (22).
- Remove the seal (26) with a flat screwdriver.
- Remove the piston (29) and piston rod (17).
- Remove the seal (34) with a flat screwdriver.
- Remove the ring (33) with a half round tongs.
- Remove the seal (27).
- Remove the seal (24).
- Remove the ring (30) with a half round tongs.
- Remove the scraper seal (32) with a flat screwdriver.
- Remove the seal (31) with a flat screwdriver.

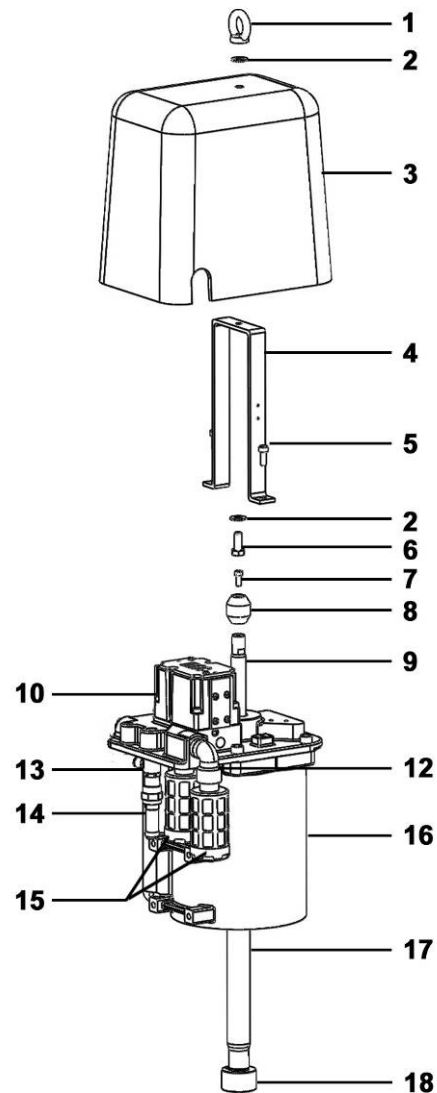

Assembly

⚠ Grease slightly the seals.

- Install the seal (31) into the cylinder.
- Install the scraper seal (32) into the cylinder.
- Install the ring (30) with a half round tongs.
- Install the seal (24) on the cylinder.
- Install the seal (27) into the cover.
- Install the seal (26) into the cover.
- Install the ring (33) with a half round tongs on the piston (29) and piston rod (17) assembly.
- Install the seal (34) in the piston grooves (29).
- Lubricate the cylinder (16).

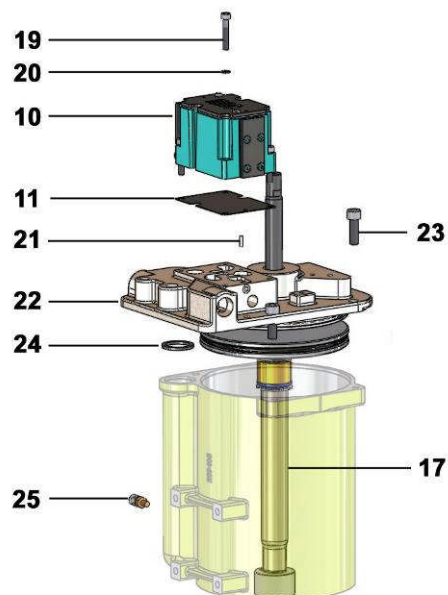

- Install the piston (29) and piston rod (17) assembly into the cylinder (16).
- Replace the cover (22) on the cylinder (16).
- Screw the 4 screws (23) with a hexagon key size 6mm.
- Install the cam (8) on the piston rod (17).
- Screw the screw (7) with a hexagon key size 4mm.
- Install the u-bolt (4) on the cover (22).
- Screw the screw (5) with a hexagon key size 5mm
- Install the elbows (41) on the switches (52).
- Connect the hoses (42) on the elbows (45).
- Replace the cover (3).
- Put the washer (2).
- Screw the hoisting ring (1).

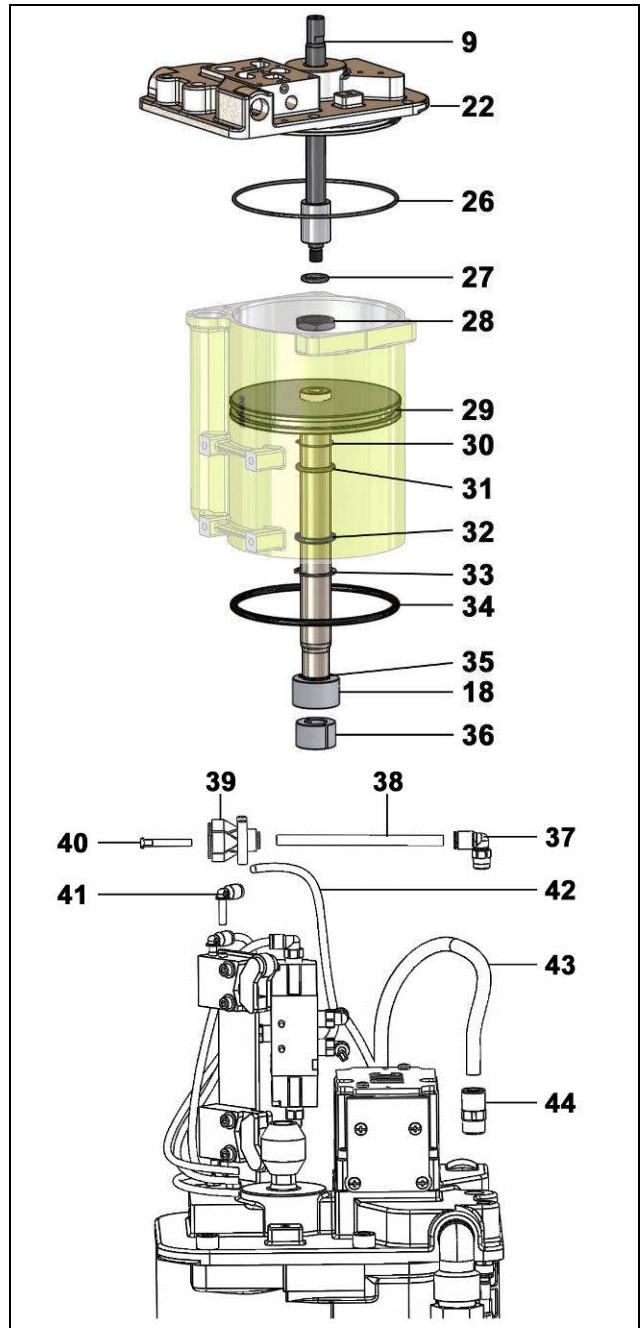

▪ DEGREES OF WEAR

The wetted parts in contact with the material are subject to wear with time. It depends, of course, on the rates and duration of pump operating; also on the material handled.

Under normal operating and servicing conditions, with standard filled material not including foreign matters or chemically aggressive, the average working life can be estimated as :

- **1 million strokes for the tightness seals.**
- **10 millions strokes for the bellows.**

FLUID SECTION ASSEMBLY INSTRUCTIONS

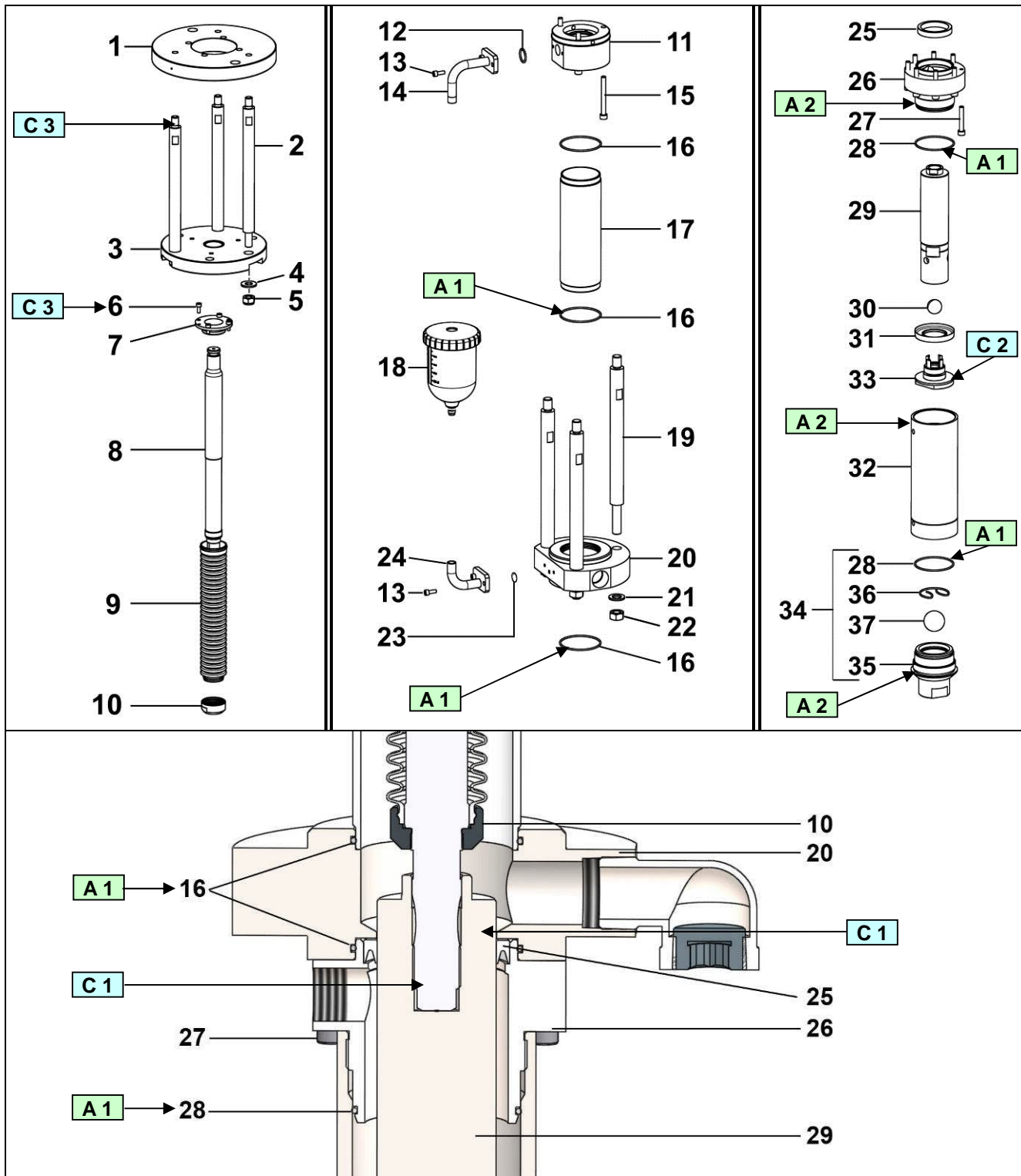

MOTOR ASSEMBLY INSTRUCTIONS

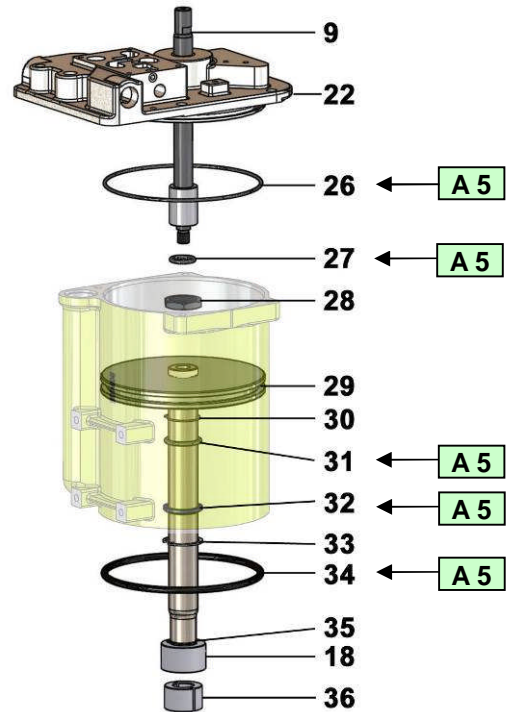
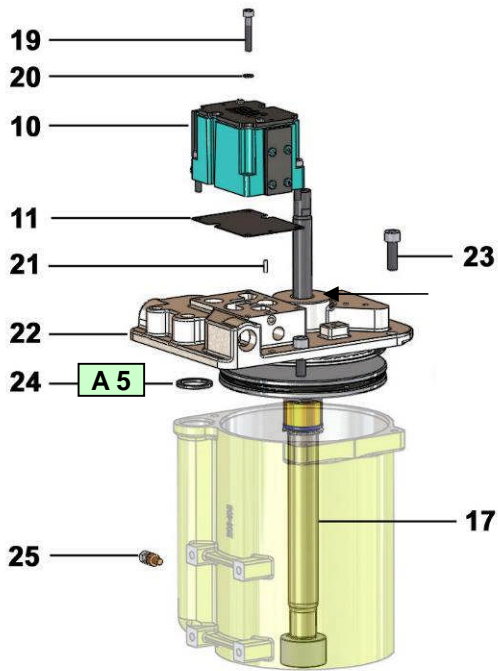
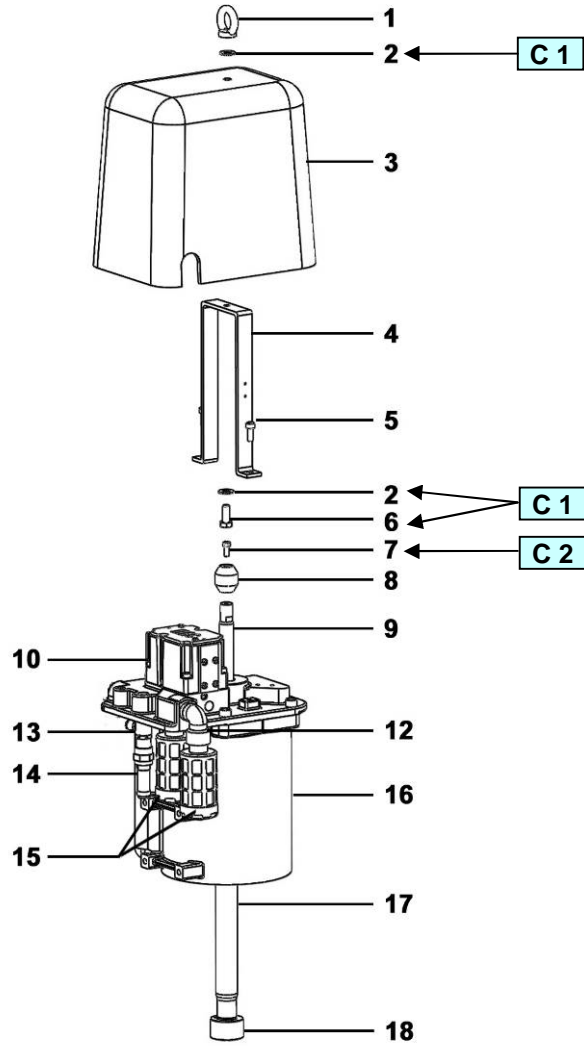

Index	Instruction	Description	Part number
A 1	PTFE grease	'TECHNILUB' grease (10 ml / 0.0026 US gal)	560.440.101
A 2	Anti-seize grease	Grease box (450 g / 0.99 lb)	560.420.005
A 5	High-performance lubricating grease	Grease box Kluber petamo GHY 133N (1 kg / 2.204 lb)	560.440.005
C 1	Medium strength Aneorobic Pipe sealant	Loctite 577 (250 ml / 0.066 US gal)	554.180.015
C 2	Low strength - Aneorobic Adhesive	Loctite 222 (50 ml / 0.013 US gal)	554.180.010
C 3	High strength - Aneorobic Adhesive	Loctite 270 (50 ml / 0.013 US gal)	554.180.004