

**GUIDE DE DEPANNAGE  
TROUBLESHOOTING  
FEHLERSUCHE  
INCIDENCIAS DE  
FUNCIONAMIENTO**

**PISTOLET AIRMIX® / AIRMIX® GUN  
AIRMIX® HANDSPRITZPISTOLE / PISTOLA AIRMIX®**

NOTICE ORIGINALE  
/ TRANSLATION OF THE ORIGINAL MANUAL  
/ ÜBERSETZUNG DER ORIGINALBEDIENUNGSANLEITUNG  
/ TRADUCCIÓN DEL LIBRO ORIGINAL

AVANT CHAQUE OPERATION DE MAINTENANCE  
DO THIS BEFORE ANY MAINTENANCE ACTION  
VOR JEDER WARTUNGSARBEIT IST FOLGENDES ZU TUN  
ANTES DE CADA OPERACIÓN DE MANTENIMIENTO

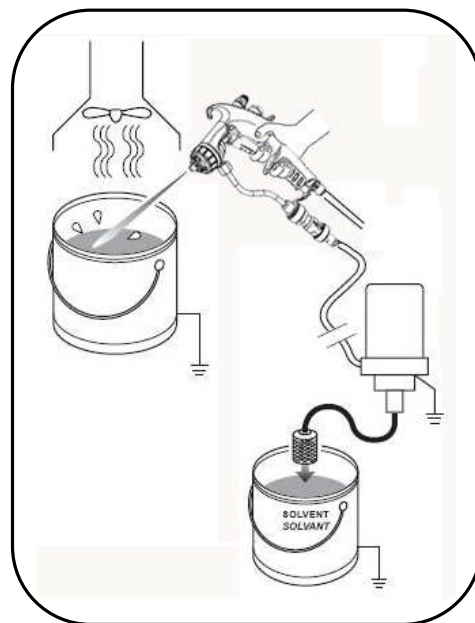
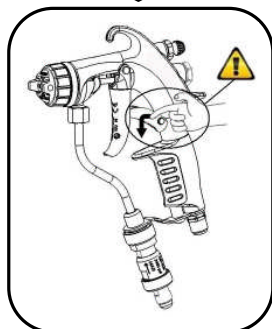
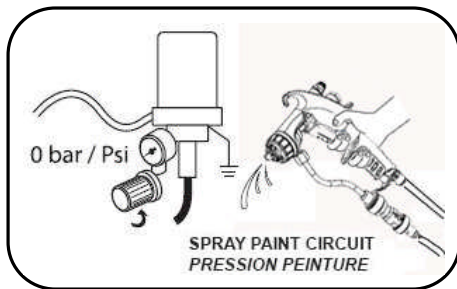

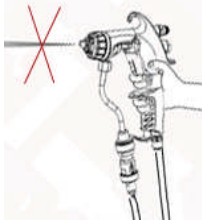

**Pas de débit**  
**No flow**  
 Kein Farbastritt aus der Pistole  
 La pintura no sale por la pistola



**Débit faible**  
**Low flow rate**  
 Zu wenig Materialausbringung  
 Caudal bajo



**Jet déformé**  
**Spray fan not uniform**  
 Spritzbild ungleichmäßig  
 Chorro deformado

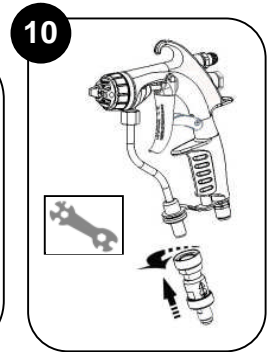
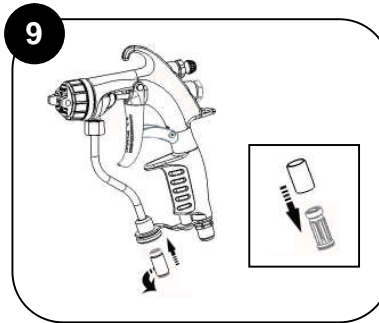
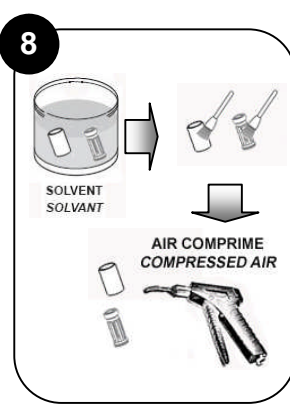
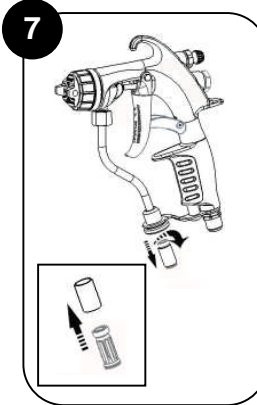
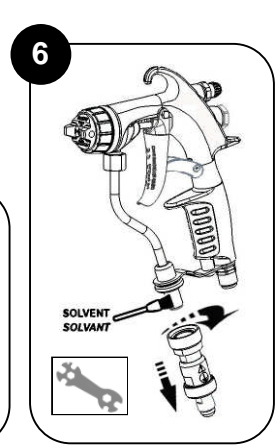
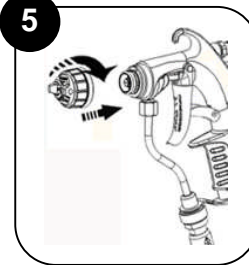
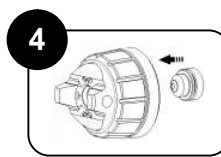
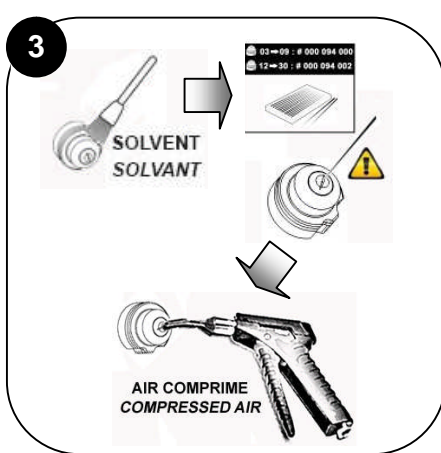
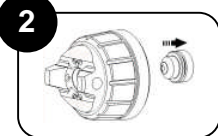
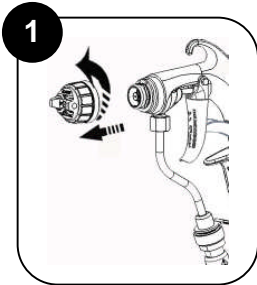

**Jet déformé**  
**Spray fan not uniform**  
 Spritzbild ungleichmäßig  
 Chorro deformado

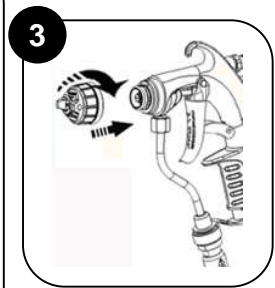
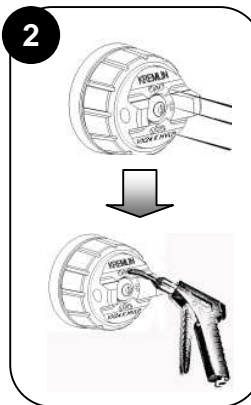
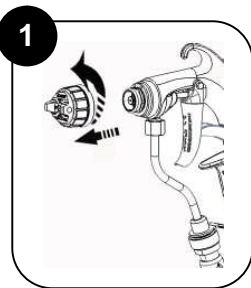

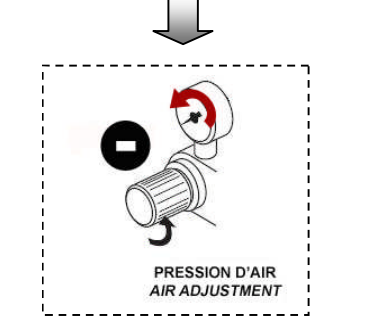
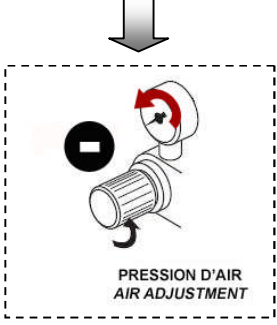
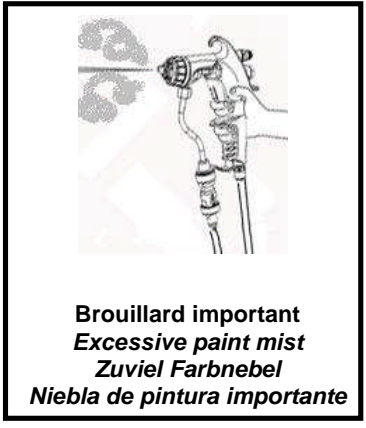
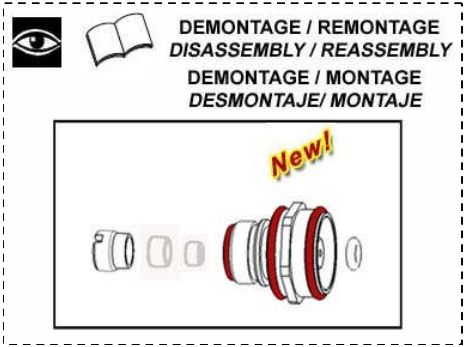
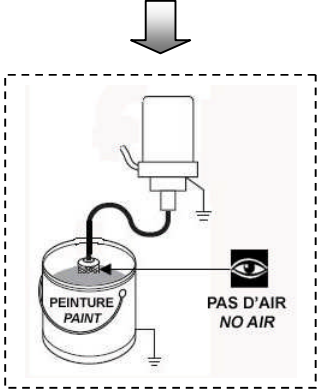
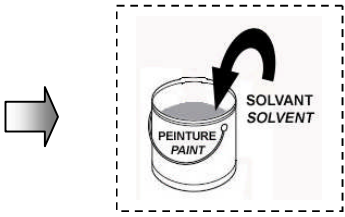
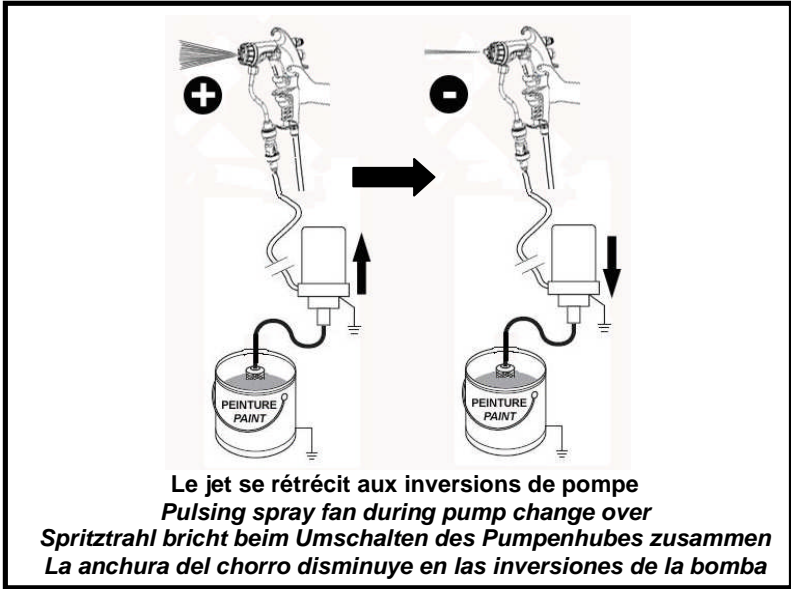

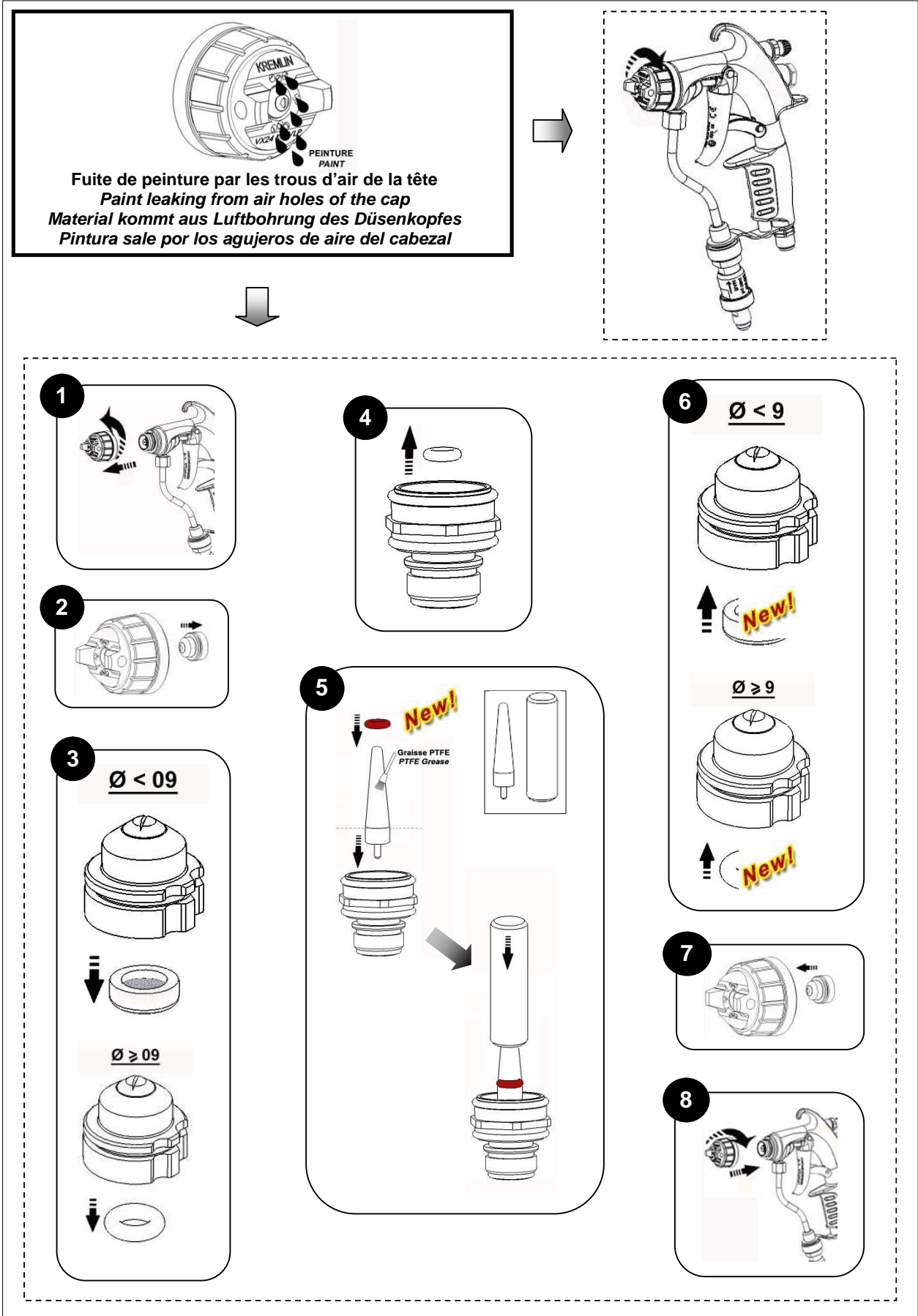



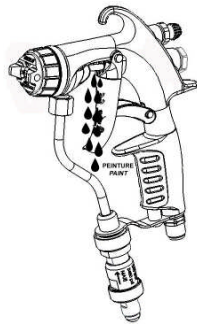



Fuite de peinture devant la gâchette  
*Paint leaks in front of the trigger*  
 Materialaustritt an der Farbnadel beim Abzugshebel  
 Fuga de pintura delante del gatillo



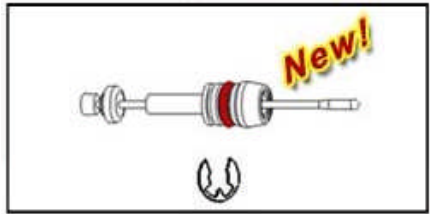

 DEMONTAGE / REMONTAGE  
 DISASSEMBLY / REASSEMBLY  
 DEMONTAGE / MONTAGE  
 DESMONTAJE / MONTAJE





Goutelettes de peinture continues en sortie de buse  
*Paint leaks continuously from the spray tip*  
 Andauernde Materialtröpfchen am Düsenkopf  
 Gotas de pintura salen de la boquilla en continuo





 DEMONTAGE / REMONTAGE  
 DISASSEMBLY / REASSEMBLY  
 DEMONTAGE / MONTAGE  
 DESMONTAJE / MONTAJE



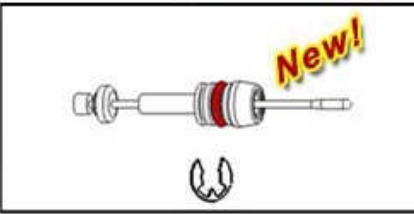
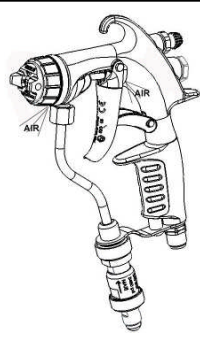

 DEMONTAGE / REMONTAGE  
 DISASSEMBLY / REASSEMBLY  
 DEMONTAGE / MONTAGE  
 DESMONTAJE / MONTAJE

Fuite d'air à l'avant du pistolet et/ou à l'arrière de la gâchette  
*Air leaking from air cap or / and behind the trigger*  
 Beständiger Luftaustritt am Düsenkopf  
 Fuga de aire por la parte delantera de la pistola y / o por la parte trasera del gatillo





 DEMONTAGE / REMONTAGE  
 DISASSEMBLY / REASSEMBLY  
 DEMONTAGE / MONTAGE  
 DESMONTAJE / MONTAJE

