



INSTRUCTION MANUAL

WAX UNIT

107 298 0303

Manual : 574.338.112 - 0806

Date : 9/06/08 - Supersede :

Modif.:

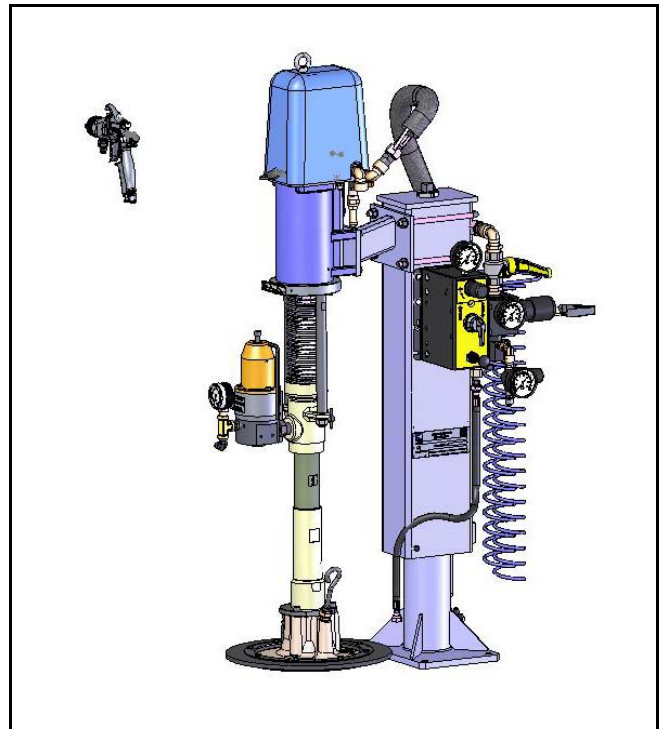

IMPORTANT : Read and understand all instructions before storing, installing and operating concerned equipment (professional use only).

PICTURES AND DRAWINGS ARE NOT CONTRACTUAL. THE MATERIAL MAY BE CHANGED WITHOUT PRIOR NOTICE

KREMLIN REXSON – 150, avenue de Stalingrad
93 245 - STAINS CEDEX - FRANCE
Téléphone : 33 (0)1 49 40 25 25 - Fax : 33 (0)1 48 26 07 16



SUMMARY

1. EC DECLARATION OF CONFORMITY.....3

2. WARRANTY3

3. SAFETY INSTRUCTIONS3

4. INSTALLATION4

5. OPERATING PRINCIPLE5

6. TECHNICAL FEATURES5

7. STARTING UP6

8. ADJUSTMENTS8

9. SHUTDOWN AT THE END OF THE WORK8

10. CHANGING THE DRUM8

11. MAINTENANCE.....9

12. TROUBLESHOOTINGS9

13. MAINTENANCE.....9

14. SPARE PARTS' LIST10

ADDITIONAL DOCUMENTATIONS

| Description | # |
|----------------------------|--|
| Motor, model 1500 | Doc. 574.201.110 |
| Fluid section, model 106cc | Doc. 574.204.110 |
| Plate, model Ø 305 | Doc. 574.051.110 |
| Ram | Doc. 574.292.110 |
| Pneumatic assembly | Doc. 574.339.110 |
| Fluid regulator | Doc. 573.008.210 + 573.041.210 + 573.328.050 |
| Gun, model M 22 HPA | Doc. 573.010.210 + 573.055.210 + 573.323.050 |

Dear Customer,

You are the owner of our new pressure regulator and we would like to take this opportunity to thank you. To make sure your investment will provide full satisfaction, special care has been taken by KREMLIN REXSON during all designing and manufacturing processes.

To obtain the best result, safe and efficient operation of your equipment, we advice you to read and make yourself familiar with this instruction and service manual.

1. EC DECLARATION OF CONFORMITY

The manufacturer : **KREMLIN REXSON** with assets of 6 720 000 Euros

Head office : 150, avenue de Stalingrad 93 245 - STAINS CEDEX - FRANCE

Tel. 33 (0)1 49 40 25 25 - Fax : 33 (0)1 48 26 07 16

Herewith declares that :

| Description | Wax unit |
|--------------------|----------------|
| Equipment number : | 107 298 0303 |
| Trademark | KREMLIN REXSON |

is declared in conformity with the :

- Machinery Directive (Directive 98/37/EEC) as amended and with national implementing legislation.

Established in Stains, on February 1st 2008

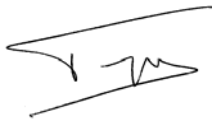

Daniel TRAGUS
President

2. WARRANTY

➔ Refer to the warranties related to the pump motor and the fluid section in the instruction manuals enclosed.

3. SAFETY INSTRUCTIONS

GENERAL SAFETY INSTRUCTIONS



CAUTION : The equipment can be dangerous if you do not use it according to the rules mentioned in this instruction manual. Read carefully all the instructions hereafter before operating your equipment.

Only trained operators can use the equipment. (To acquire an essential training, please contact the "KREMLIN REXSON University" training center - Stains).

The foreman must ensure that the operator has perfectly taken in the safety instructions of this equipment as well as the instructions in the manuals of the different parts and accessories.

Read carefully all instruction manuals, label markings before operating the equipment.

Incorrect use may result in injury. This equipment is for professional use only. It must be used only for what it has been designed for. Never modify the equipment. The parts and accessories supplied must be regularly inspected. Defective or worn parts must be replaced.

Never exceed the equipment components' maximum working pressure.

Comply with regulations concerning safety, fire risks, electricity in force in the country of final destination of the material. Use only products or solvent compatible with the parts in contact with the material (refer to data sheet of the material manufacturer).

➔ Refer to the safety instructions related to the pump, the regulator and the gun in the instruction manuals enclosed.

4. INSTALLATION



■ HANDLING

The ring located above the cover is designed for the hoisting of the motor and of the fluid section and **can not be used for the handling of the complete machine.**

■ STORING

Place the equipment safe from dampness after having closed the different air inlets and ports (plugs).

■ DESCRIPTION OF THE LABEL MARKING

| | | |
|---|---|--|
|  KREMLIN | KREMLIN REXSON Stains FRANCE |  REXSON |
| TYPE : <input style="width: 100%;" type="text"/> | | |
|  | SERIE/SERIAL N°: <input style="width: 80%;" type="text"/> | |
| INDICATIONS: <input style="width: 100%;" type="text"/> | | |
| <input style="width: 100%;" type="text"/> | | |

| | |
|---|--|
| KREMLIN REXSON STAINS FRANCE | Name and address of the manufacturer |
| TYPE xx | Unit part number : 1072980303 |
| CE | Conformity with the European directives |
| Serie / Serial | Number given by KREMLIN REXSON |
| Indications | Max P 6 bar / 87 psi Unit 17/1-106cc / PSØ305 |

■ COMPOSITION

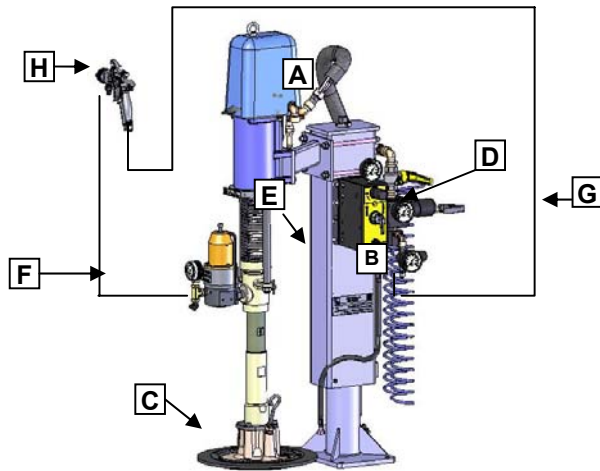

| | |
|----------|---|
| A | Shovel pump ALTO, model 17/1 - 106 cc |
| B | Single post ram |
| C | Plate, model Ø 305 |
| D | Air equipment |
| E | Fluid regulator |
| F | Material hose, model Ø 4,8 mm / 3/16 dia - Length : 5 m / 16.4 ft |
| G | Air hose, model Ø 7x13 - Length : 5 m / 16.4 ft |
| H | Pneumatic gun, model M22 HPA |

5. OPERATING PRINCIPLE

The pump motor drives the piston of the fluid section and, by its motion, the piston suctions and exhausts simultaneously the material.

The pump is fixed on a single post ram (B). It enables to get up or get down the pump.

When the air pressure exerts on the upper part of the jack, the up motion exerts downwards and the pump goes down.

When the air pressure exerts on the lower part of the jack, the up motion exerts upwards and the pump goes up.

The air equipment located on the ram controls :

- Air pressure on the pump motor,
- Air pressure on the jack ram,
- Pump up / down motion,
- Gun spraying air pressure,
- Plate extraction.

6. TECHNICAL FEATURES

| | |
|---|--------------------|
| Pump : | |
| Motor version..... | 1500 |
| Pump body version..... | 106cc |
| Pressure ratio | 17/1 |
| <i>Wetted parts :</i> | |
| Pump : Steel, steel treated stainless steel, tungsten carbide, electro galvanized steel, PTFE | |
| <i>Tightness packings :</i> | |
| Upper : PTFE-PE | |
| Lower : PTFE-PE | |
| Suction : PTFE | |
| Motor stroke | 120 mm |
| Delivery per cycle | 106 cc |
| Maximum air inlet pressure | 6 bar / 87 psi |
| Maximum fluid pressure | 102 bar / 1480 psi |
| Noise level | < 80 dBa |
| Maximum operating temperature | 80 °C / 176° F |
| Weight | 17 kg |

| | |
|--|--|
| <p>Airmix regulator : Version250 - 10/70 bar <i>Wetted parts :</i> Stainless steel, PTFE, carbide</p> | <p>Maximum fluid inlet pressure 250 bar / 3626 psi Fluid outlet pressure From 10 to 70 bar / from 145 to 1015 psi Maximum operating temperature 50°C / 122° F</p> |
| <p>Gun : Version M 22 HPA Projector 18 EN3 <i>Wetted parts :</i> Stainless steel, treated stainless steel</p> | <p>Maximum air supply pressure 6 bar / 87 psi Maximum fluid supply pressure 10 bar / 145 psi Maximum operating temperature 50°C / 122° F</p> |
| <p>Unit : <i>Connections :</i> Air inlet F 3/4 G Spraying air outlet M 1/4 NPS Fluid outlet..... M 1/2 JIC <i>Dimensions :</i> Width 393 mm / 15.5 " Height..... 1210 mm - 1683 mm / 47.6" - 66.3" Depth..... 693 mm / 27.3"</p> | <p>Noise level < 80 dBa Maximum operating temperature 50 °C / 122° F Weight 67 kg / 148 lbs</p> |

7. STARTING UP

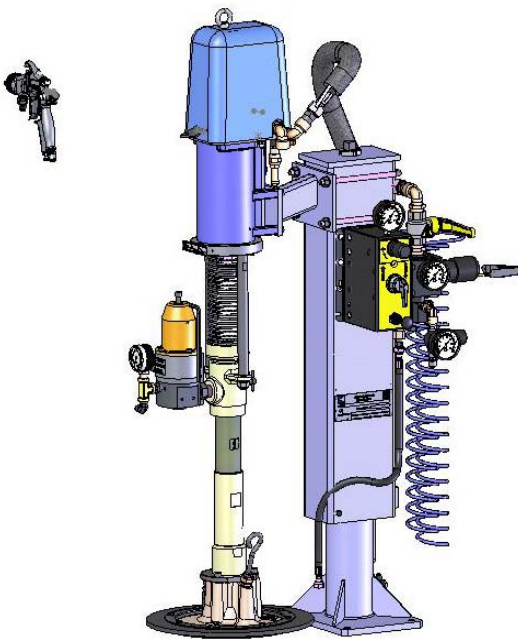

Ind. 2 + 4 : ram air pressure + drum extraction air pressure

Ind. 9 + 10 : pump air pressure

Ind. 7 + 13 : spraying air pressure

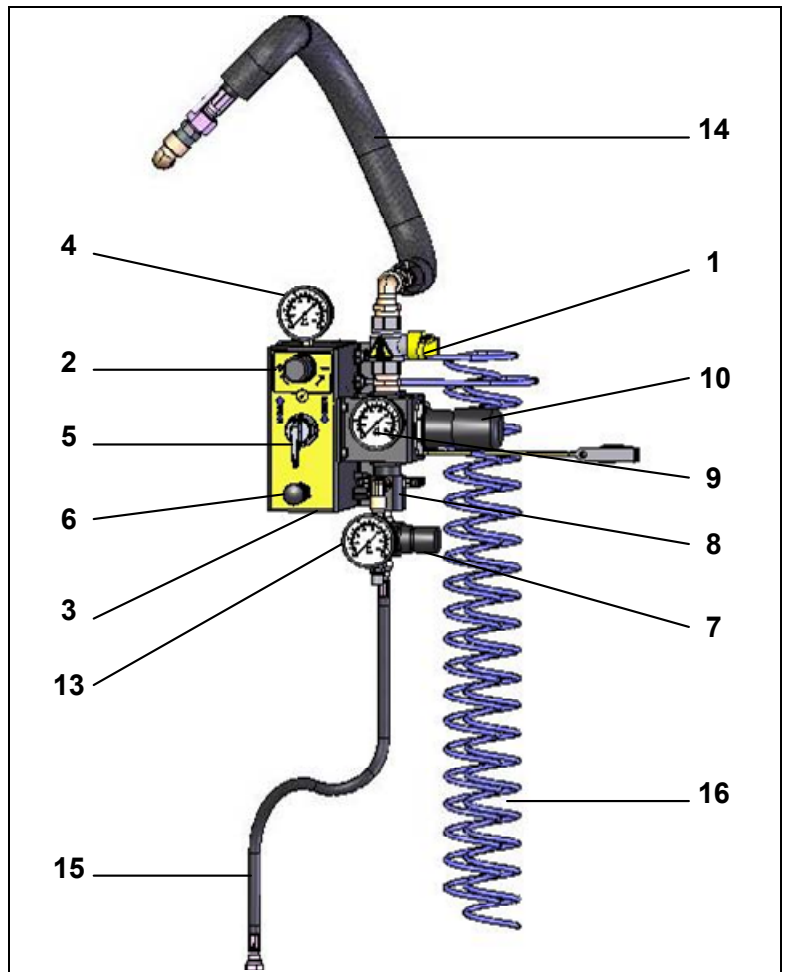



**Protective clothing (gloves, protective masks, glasses, protective clothing,...) should be worn to comply with the recommendations.
The working area must be correctly ventilated.**

■ BEFORE STARTING UP THE EQUIPMENT

Half fill the fluid section cup with T lubricant or with the appropriate cleaning solvent.

The cup nut must be slightly tightened. Make sure the components are correctly tightened (refer to the instruction manual of the fluid section). A wrench is supplied to allow a correct tightening.

Ground the pump and its accessories.

Check the fittings are correctly tightened and are in good condition (no knot, breaking, fold on the air and material hoses).



The wax unit is fitted with a ground cable. Ground the cable to a safe earth.

■ TRAINING INSTRUCTIONS

Before using the equipment, the foreman must ensure that the operators have perfectly taken in the safety instructions of this equipment as well as the instructions in the manuals of the different parts and accessories.

Before filling the pump with material, mark and carry out the handling of the release and drain valves to be familiar with the equipment and its controls.



WARNING!

The frictions due to the displacement of the fluid inside the pump and accessories, as well as the one created by the tightness seals, generate static electricity that may cause fire or explosion.

→ **The unit must be grounded (ground cable).**



**KEEP HAND AND FINGERS AWAY FROM THE PUMP FLUID INLET.
THE SHOVEL COULD LEAD TO SERIOUS INJURIES.**

■ STARTING UP

The pump and accessories are tested prior in our factory with fluid lubricant. Before starting up the equipment, you must flush them with a solvent compatible with the material to use.

To operate the wax unit, you must :

Unscrew the pneumatic adjustments' regulators.

Connect the equipment to the pneumatic network (clean air, maximum 6 bar / 87 psi).

Connect the hoses as well as the gun.

Place the 'Ram control' (5) hand lever in the central position.

Open the air supply.

Screw the 'Ram regulation' (2) regulator until reading on the gauge (4) 1 bar / 14.5 psi.

Turn the 'Ram control' (5) hand lever towards the ASCENT position. The pump must have an ascent motion. Otherwise, you must increase the pressure.

The pump is in high position :

Place the fluid drum (Ø 306) under the follower plate.

Take off the drain rod located on the plate.

Turn the 'Ram elevator' (5) hand lever towards the DESCENT position.

As soon as the fluid flows out from the drain hole, install the rod. If no fluid comes out from the drain hole, increase the 'Ram regulation' pressure.

Leave the 'Ram control' (5) in the low position.

Screw the 'Pump regulation' (10) regulator until reading on the corresponding gauge (9) **1 or 2 bar / 14.5 to 29 psi**. The pump must operate.

➤ *Nota : To prevent from a too important fluid pressure at the pump outlet, a safety valve, located on the unit air equipment, limits the pump motor air supply pressure (valve setted to 3.8 bar / 55 psi).*

Point the gun towards an empty drum and trigger the gun.

Tighten the fluid regulator adjustment screw until reading on the gauge a pressure between 3 and 10 bar / 43.5 to 145 psi.

Open the gun and leave it on the edge of the drum (grounded) to drain off air into the hose, the gun.

Extrude the material until there is no more air.

Install the cap and adjust the pressure according to the required flow rates.

8. ADJUSTMENTS

If the fluid overflows on the drum around the seal, unscrew the 'Ram regulation' (2) air regulator to reduce the pressure.

If the pump races, it means that it does not suction material. Screw the 'Ram regulation' air regulator (2) to increase the pressure on the follower plate.

Make sure the pump strokes to a rhythm lower to 20 strokes/minute.

| Fluid flow rate too important | Fluid flow rate too low |
|---|---|
| ↓ | ↓ |
| Unscrew the fluid regulator (E) | Screw the fluid regulator (E) |
| Or unscrew the 'pump regulation' air regulator (10) | Or screw the 'pump regulation' air regulator (10) |
| Or use a nozzle with a little diameter. | Or use a larger and shorter hose |
| | Or use a bigger nozzle |

9. SHUTDOWN AT THE END OF THE WORK

Leave the 'Ram control' hand lever in DESCENT position (5).

We advice you to stop the pump in 'low inversion' position to prevent material spreading on the piston rod.

Disconnect the compressed air supply.

The pump must be filled with material. The follower plate, in contact with the material, acts as a cover to prevent from the material drying.

Whatever the case, when stopping the pump, always leave it filled with material.
For a short duration shutdown, if the flushing has not been carried out, leave the pump filled with material.
For a long duration shutdown, after flushing the pump, leave it filled with clean solvent.

10. CHANGING THE DRUM

Unscrew the 'pump regulation' (10) regulator to its maximum.

Decrease the air pressure on the jack around 1 bar / 14.5 psi (2+4).

Drive the hand lever (5) towards the 'ASCENT' position until the ram levers up the pump and the drum 5 cm / 1.97" from the floor.

Place the 'ASCENT - DESCENT' hand lever (5) on the intermediate position.

Press the 'drum extraction' push button (6). Air is sent under the plate to separate the plate from the bottom of the drum.



WARNING! The drum extraction pressure is given by means of the 'Ram regulation' regulator (2).

Do not exceed a pressure of 1 bar / 14.5 psi (reading on the gauge 4).

Drive the hand lever (5) towards the 'ASCENT' position. The pump must lever up and the empty drum must stay on the floor.

Change the fluid drum.

To start once again the equipment, refer to 'STARTING UP' page.

11. MAINTENANCE



WARNING!

Before any intervention on a component of the wax unit, shut off the compressed air supply and depressurize the systems by triggering the gun.

■ SPRAY GUN

Comply with the usual instructions of the spray gun servicing (refer to the gun instruction manual).

■ REGULATOR

Comply with the usual instructions of the spray gun servicing (refer to the regulator instruction manual).

■ PUMP

Regularly change the lubricant on the pump wetting cup (this lubricant will normally be coloured).

Check the cup is clean and clean it regularly with solvent after having drained the lubricant.

When changing the drum :

- Check the plate seal condition,
- Clean over and underneath the follower plate.

12. TROUBLESHOOTINGS

Refer to the instruction manuals of the motor, the fluid section, the regulator and the gun.

13. MAINTENANCE

Refer to the instruction manuals of the motor, the fluid section, the regulator and the gun.

14. SPARE PARTS' LIST

Wax unit

107 298 0303

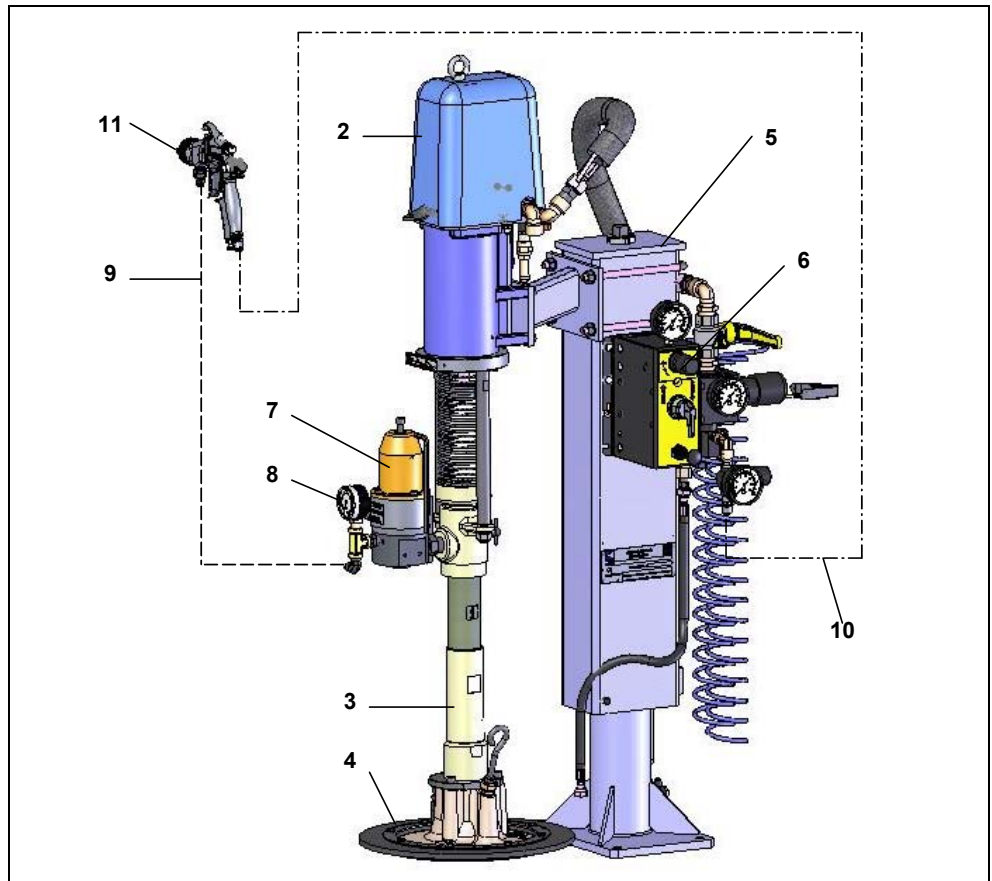

| Ind. | # | Description | Qty |
|------|-----------------|---|-----|
| 1 | 42 135 182 0203 | ALTO shovel pump, model 17/1 - 106cc | 1 |
| 2 | 106 021 | ▪ Motor, model 1500 | 1 |
| 3 | 105 182 0203 | ▪ ALTO fluid section, model 106cc | 1 |
| 4 | 105 491 0001 | Plate, model Ø 306 mm | 1 |
| 5 | 105 654 | Single post ram | 1 |
| 6 | 107 305 | Air equipment | 1 |
| 7 | 155 271 730 | Fluid regulator, model 240 bar - 3481 psi from 10 to 70 bar | 1 |
| 8 | 910 010 802 | Fluid gauge (0 - 120 bar) | 1 |
| 9 | 050 450 801 | Material hose Ø 4,8 mm - Lg. 5m - fitting : 1/2 JIC | 1 |
| 10 | 050 382 109 | Air hose | 1 |
| 11 | 135 145 207 | Gun, model M 22 HPA (18 N3) | 1 |

OPTIONS

Drum centring and
clamping
106 124



Base
210 109

