



INSTRUCTION MANUAL

PNEUMATIC REGULATORS 3 & 4 PLATES

106 621 0131 - 106 621 0141 - 106 621 0241

Manual : 574.014.112 - 0601

***Date : 03/01/06 - Supersede :
Modif.***

IMPORTANT : Read and understand all instructions before storing, installing and operating concerned equipment (professional use only).

PICTURES AND DRAWINGS ARE NOT CONTRACTUAL. THE MATERIAL MAY BE CHANGED WITHOUT PRIOR NOTICE.

**KREMLIN REXSON – Site de Stains : 150, avenue de Stalingrad
93 245 - STAINS CEDEX - FRANCE
Téléphone : 33 (0)1 49 40 25 25 - Fax : 33 (0)1 48 26 07 16**



**INSTRUCTION MANUAL
PNEUMATIC REGULATORS
3 & 4 PLATES**

SUMMARY

01. EC DECLARATION OF CONFORMITY	2
02. WARRANTY	2
03. SAFETY INSTRUCTIONS	3
04. EXPLODED VIEW	7
05. SPARE PARTS' LIST	8
06. TECHNICAL FEATURES	10
07. START UP	10
08. DISASSEMBLY	10
09. ASSEMBLY	11
10. MAINTENANCE	11
11. TROUBLESHOOTING CHART	12

Dear Customer,

You are the owner of our new equipment and we would like to take this opportunity to thank you.

To make sure your investment will provide full satisfaction, special care has been taken by KREMLIN REXSON during all designing and manufacturing processes.

To obtain the best result, safe and efficient operation of your equipment, we advice you to read and make yourself familiar with this instruction and service manual. Indeed, the non-compliance with instructions and precautions stated in this manual could reduce the equipment working life, result in operating trouble and create unsafe conditions.

01. EC DECLARATION OF CONFORMITY

The manufacturer : **KREMLIN REXSON** with assets of 6 720 000 Euros

Head office : 150, avenue de Stalingrad 93 245 - STAINS CEDEX - FRANCE

Tel. 33 (0)1 49 40 25 25 - Fax : 33 (0)1 48 26 07 16

Herewith declares that : Pneumatic regulator, is in conformity with the provisions of :

EC - Machinery Directive (Directive 98/37/EEC) as amended and with national implementing legislation.

Established in Stains, on March 1 st 2003,

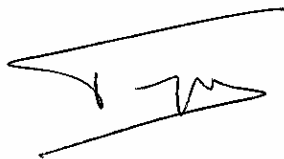

Daniel TRAGUS
President

02. WARRANTY

We reserve the right to make changes; these changes may be carried out after the receipt of the order. No claim will be accepted as a consequence of any change carried out in the instruction manuals or in the selection guides.

Our equipment is checked and tested prior to shipment. In the case of a problem arising with the equipment, this must be in writing, within ten days from the delivery date.

KREMLIN REXSON warrants all equipment manufactured bearing its name, to be free from defect in material or workmanship for a period of 12 months (one shift per day or 1800 hours - 1 term reached) from the date of delivery. Work life is based on single shift working - 8 hours per day. Warranty claims for defective items will only be accepted in writing and will be verified and confirmed by us.



















The warranty does not cover fair wear and tear, damage or wear caused by misuse, improper maintenance or non-observance of our recommendations.

KREMLIN REXSON will repair or replace parts (carriage paid to our plant and accepted as defective by us). We shall not be liable for any losses, resulting from a production breakdown. Upon request, we can carry out service work at your premises; all expenses (travelling and accommodation) for KREMLIN REXSON technicians will be chargeable.

In the event that it is found that equipment has been tampered with, this will invalidate the warranty. Equipment that it is bought in will be subject to the suppliers' warranty.

03. SAFETY INSTRUCTIONS

PICTOGRAMS

	NIP HAZARD		READ THE USER INSTRUCTIONS MANUAL
	DO NOT EXCEED THIS PRESSURE		WARNING MOVING ELEVATOR
	WARNING MOVING SHOVEL		WARNING MOVING PARTS
	HIGH PRESSURE HAZARD		RELIEF OR DRAIN VALVE
	WARNING HOSE UNDER PRESSURE		WEAR OF GLOVE IS OBLIGATORY
	WEAR GLASSES OBLIGATORY		PRODUCT VAPOR HAZARDS
	ELECTRICAL HAZARD		WARNING FIRE HAZARDS
	WARNING HOT PARTS OR AREAS		EXPLOSION HAZARDS
	GROUNDING		WARNING (USER)
	WARNING SERIOUS INJURIES		

GENERAL SAFETY INSTRUCTIONS

Before using the equipment, please ensure the operator has read and understood all instructions and warnings of this instruction manual as well as the instructions in the manuals of the different parts and accessories.

Incorrect use may result in injury. This equipment should only be used by trained operators. It must be used only for what it has been designed for. Never modify the equipment. The parts and accessories supplied must be genuine KREMLIN REXSON parts and conform with our specifications. The equipment must be regularly inspected. Defective or worn parts must be replaced.

Never exceed the components maximum working pressure of the equipment.

Comply with regulations concerning safety, fire risks, electricity in force in the country of final destination of the material. Use only products or solvents compatible with the parts in contact with the material (refer to data sheet of the material manufacturer).

PRESSURE HAZARDS



Current legislation requires that an air relief shut off valve is mounted on the supply circuit of the pump motor to let air off when closing the supply circuit. Without this precaution, the motor residual air of the motor may let the pump beat and cause a serious injury.

Please ensure that, a material drain valve is mounted on the material circuit to drain it (after shutting down air to the motor and the pressure relief) before any servicing on the equipment. These valves must be closed for air and opened for product when processing.

HIGH PRESSURE INJECTION HAZARDS



When working with high pressure equipment, special care is required. Fluid leaks can occur. Then there are injection risks in exposed parts of body that may cause severe injuries or amputations.

- Medical care must be handled immediately if product is injected under the skin or in other parts of the body (eyes, fingers).
- Never point the spray gun at anyone. Never try to stop the spray with your hands or fingers nor with rags or similars.
- **Follow the shutdown procedure and always depressurize air and fluid circuits** before carrying out any servicing on the gun (cleaning, checking, maintenance of the material or cleaning of the gun nozzles).
- For the guns equipped with a safety device, always lock the trigger when you do not start the gun.

FIRE - EXPLOSION - SPARKS- STATIC ELECTRICITY HAZARDS



A poor earth connection, inadequate ventilation, sparks, or static electricity can cause an explosion or fire. To avoid these risks when using or servicing KREMLIN REXSON equipment, the following safety procedures must be followed:

- ensure a good earth connection and ground the parts to be handled i.e. solvents, materials, components and equipment,
- ensure adequate ventilation,
- keep working area clean and free from waste solvents, chemicals, or solid waste i.e. rags, paper and empty chemical drums,
- never use electrical switches / power if in an atmosphere of volatile solvent vapour,
- stop immediately working in case of electrical arcs,
- never store chemicals and solvents in the working area.

TOXIC PRODUCT HAZARDS

Toxic products or vapours can cause severe injury not only through contact with the body, but also if the products are ingested or inhaled.



It is imperative :

- to know the material products and their risks,
- notified or hazardous materials must be stored in accordance with the regulations,
- the materials must be used in an appropriate container, never place materials in a container where there is a risk of spillage or leakage,
- a procedure must be applied for the safe disposal of waste material. It must comply with all the prevailing regulations and legislations of the country where the equipment is to be used,
- protective clothing should always be worn in compliance with the material manufacturers recommendations,
- depending on the application and chemical safety instructions, safety glasses, gloves, foot wear, protective masks and possible breathing equipment should be worn to comply with the regulations. (Refer to chapter "Safety equipment" of KREMLIN selection guide).



CAUTION!

It is forbidden using any solvents or with halogenated hydrocarbon base and also products made with these solvents facing **aluminium** and **zinc**. The non-compliance with the instructions may cause explosion hazards causing serious or fatal injuries.

EQUIPMENT REQUIREMENTS

PUMP



Before carrying out any work, it is imperative to get used with the compatibilities of motors with pumps before coupling. The operator shall understand the equipment and the safety instructions. These instructions are available in the manuals of the pumps.

The air motor is designed to be mounted with a pump. Never modify any components or couplings. When operating, please keep hands away from moving parts. Before starting up the equipment, please read the PRESSURE RELIEF INSTRUCTIONS. Please ensure that any relief or drain valves fitted are in good working order.

HOSES

- Keep hoses out of circulation areas, moving parts or hot surfaces.
- Never expose product hoses to temperatures higher than + 60°C / 140° F or lower than 0°C / 32° F.
- Never pull or use the hoses to move the equipment.
- Tighten all fittings as well as the hoses before operating the equipment.
- Check the hoses regularly, change them if they are damaged

Never exceed the working pressure indicated on the hose (WP).

USED PRODUCTS

Considering the variety of products that may be used by the users and the impossibility to check off all chemical data, of possible reactions of chemicals to each other and their long term evolution, KREMLIN REXSON can not be considered as liable for :

- The bad compatibility of wetted parts,
- Risks for staff and surroundings, for worn or out of order parts, for wrong working of equipments or units, as well as for the qualities of final product,
- The user must know and prevent the possible risks owing to toxic vapours, fires or explosions due to used products. He shall determine the risks of immediate reactions or the cumulative effects pursuant to repeated exposures of the staff.
- KREMLIN REXSON shall not be liable for expenses or claims or psychic injuries or direct or indirect material damages further to the use of chemicals.

04. EXPLODED VIEW

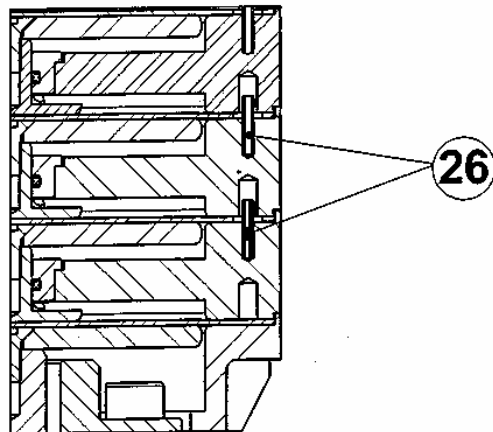
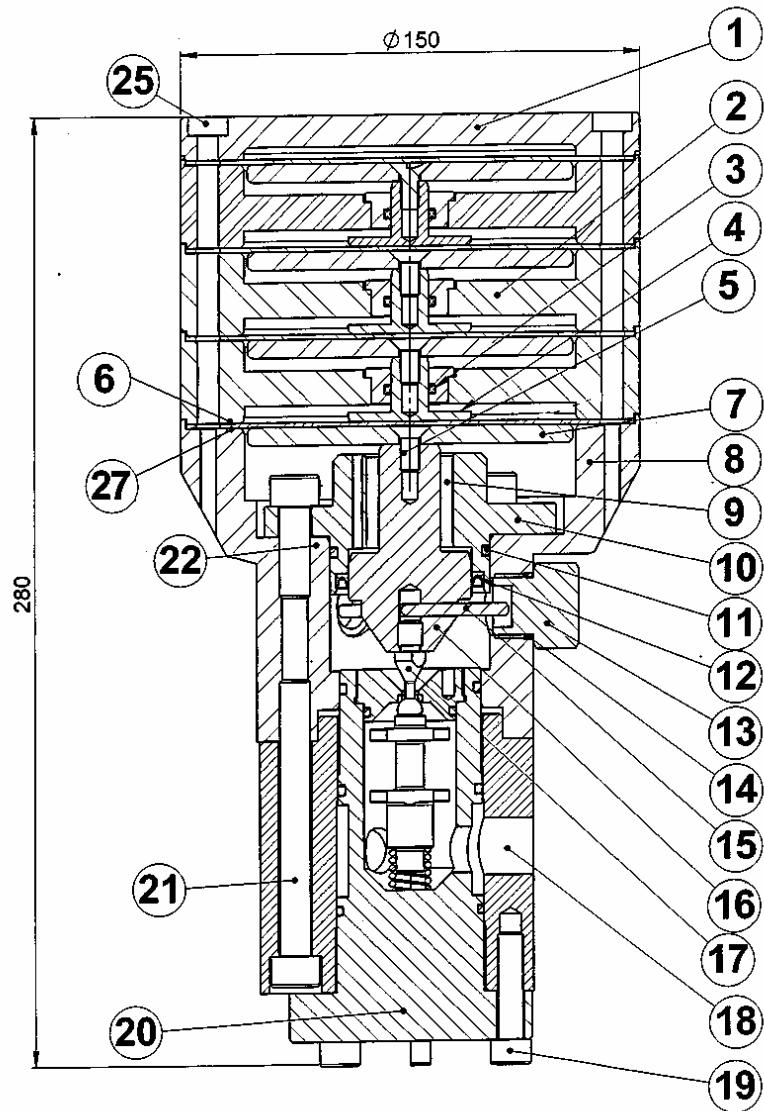

05. SPARE PARTS' LIST

COMMON PARTS						
<i>(*the first number indicates the quantities for the regulator- 3 plates, the second number the quantities for the regulators - 4 plates)</i>						
Ind	#	Désignation	Description	Bezeichnung	Denominación	Qté
1	204 819	Couvercle	Cover	Deckel	Tapa	1
2	204 822	Entretoise	Spacer	Muffe	Tirante	2/3*
4	204 821	Butée	Stop	Anschlag	Tope	2/3*
5	204 915	Vis	Screw	Schraube	Tornillo	3/4*
7	204 820	Plateau	Plate	Platte	Plato	3/4*
8	211 374	Corps	Body	Körper	Cuerpo	1
9	90 025	Douille à bille	Ball bearing	Kugelbuchse	Pico de bolas	1
10	204 823	Clapet	Valve	Ventil	Valvula	1
13	211 379	Bouchon	Plug	Stöpsel	Tapón	2
15	211 378	Goupille	Pin	Splint	Pasador	1
16	204 828	Tige de clapet	Valve rod	Ventilstange	Eje de válvula	1
18	211 375	Bloc d'entrée	Inlet block	Eingangsspeicher	Bloque de entrada	1
19	930 151 446	Vis	Screw	Schraube	Tornillo	4
21	88 177	Vis	Screw	Schraube	Tornillo	4
22	88 189	Vis	Screw	Schraube	Tornillo	4
26	88 427	Goupille	Pin	Splint	Pasador	2
	203 683	Plaquette de pression	Pressure plate	Druckplatte	Placa de presión	1
	906 030 107	Rivet	Rivet	Niet	Roblón	2

SPECIFIC PARTS						
Ind	#	Désignation	Description	Bezeichnung	Denominación	Qté
106 621 0131 : Regulator - 3 plates						
17	631 143	Poussoir	Push rod	Drücker	Pulsador	1
20	106 622	Cartouche	Cartridge	Packung	Cartucho	1
25	88 140	Vis	Screw	Schraube	Tornillo	8
*	106 623	Pochette de joints	Package of seals	Dichtungssatz	Bolsa de juntas	1
106 621 0141 : Regulator - 4 plates						
17	631 143	Poussoir	Push rod	Drücker	Pulsador	1
20	106 622	Cartouche	Cartridge	Packung	Cartucho	1
25	88 617	Vis	Screw	Schraube	Tornillo	8
*	106 652	Pochette de joints	Package of seals	Dichtungssatz	Bolsa de juntas	1
106 621 0241 : Special Regulator - 4 plates						
17	211 477	Poussoir	Push rod	Drücker	Pulsador	1
20	106 622 0201	Cartouche spéciale	Cartridge	Spezial Packung	Cartucho	1
25	88 617	Vis	Screw	Schraube	Tornillo	8
*	107 149	Pochette de joints	Package of seals	Dichtungssatz	Bolsa de juntas	1

PACKAGE OF SEALS						# 106 623
Ind	#	Désignation	Description	Bezeichnung	Denominación	Qté
* 6	NCS/NSS	Membrane	Diaphragm	Membran	Membrana	3
* 3	NCS/NSS	Joint NBR	NBR seal	NBR Dichtung	Junta NBR	2
* 12	NCS/NSS	Joint	Seal	Dichtung	Junta	1
* 11	NCS/NSS	Joint FKM	FKM seal	FKM Dichtung	Junta FKM	1
* 14	NCS/NSS	Joint FKM	FKM seal	FKM Dichtung	Junta FKM	2
*	NCS/NSS	Joint FKM	FKM seal	FKM Dichtung	Junta FKM	1
*	NCS/NSS	Joint FKM	FKM seal	FKM Dichtung	Junta FKM	1
*	NCS/NSS	Joint torique VITON	VITON O-Ring	VITON O'Ring	Junta tórica VITON	1
*	NCS/NSS	Joint FKM	FKM seal	FKM Dichtung	Junta FKM	1

PACKAGE OF SEALS						# 106 652
Ind	#	Désignation	Description	Bezeichnung	Denominación	Qté
* 6	NCS/NSS	Membrane	Diaphragm	Membran	Membrana	4
* 3	NCS/NSS	Joint NBR	NBR seal	NBR Dichtung	Junta NBR	3
* 12	NCS/NSS	Joint	Seal	Dichtung	Junta	1
* 11	NCS/NSS	Joint FKM	FKM seal	FKM Dichtung	Junta FKM	1
* 14	NCS/NSS	Joint FKM	FKM seal	FKM Dichtung	Junta FKM	2
*	NCS/NSS	Joint FKM	FKM seal	FKM Dichtung	Junta FKM	1
*	NCS/NSS	Joint FKM	FKM seal	FKM Dichtung	Junta FKM	1
*	NCS/NSS	Joint torique VITON	VITON O-Ring	VITON O'Ring	Junta tórica VITON	1
*	NCS/NSS	Joint FKM	FKM seal	FKM Dichtung	Junta FKM	1

PACKAGE OF SEALS						# 107 149
Ind	#	Désignation	Description	Bezeichnung	Denominación	Qté
* 6	NCS/NSS	Membrane	Diaphragm	Membran	Membrana	4
* 27	NCS/NSS	Membrane PTFE	PTFE diaphragm	PTFE Membran	Membrana PTFE	4
* 3	NCS/NSS	Joint NBR	NBR seal	NBR Dichtung	Junta NBR	3
* 11	NCS/NSS	Joint FKM	FKM seal	FKM Dichtung	Junta FKM	1
* 12	NCS/NSS	Joint FKM	FKM seal	FKM Dichtung	Junta FKM	1
* 14	NCS/NSS	Joint FKM	FKM seal	FKM Dichtung	Junta FKM	2

- * Pièces de maintenance préconisées tenues en stock
- * Preceding the index number denotes a suggested spare part.
- * Bezeichnete Teile sind empfohlene Ersatzteile.
- * Piezas de mantenimiento preventivo a tener en stock.

- N C S : Non commercialisé seul.
- N S S : Denotes parts are not serviceable separately.
- N S S : Bezeichnete Teile gibt es nicht einzeln, sondern nur komplett.
- N C S : no suministrado por separado.

06. TECHNICAL FEATURES

Fluid inlet port : Ø 3/4"G

Fluid outlet port : Ø 3/4"G

Regulation air inlet port : Ø 1/4"G

5,4 mm / 0.21" (ball : 8 mm / 0.32")

Inlet maximum pressure : 400 bars / 5801 psi

Regulated outlet minimum pressure : ~ 5 bars / 72.5 psi

Regulated outlet maximum pressure : 160 bars / 2320.5 psi for 6 bars / 87 psi of air for the regulators, model 4 plates,

120 bars / 1740.4 psi for 6 bars / 87 psi of air for the regulators, model 3 plates,

Regulation air pressure : 6 bars / 87 psi.

07. START UP

The regulators are tested in our plant with neutral oil.

Before starting the equipment, you must eliminate the oil flushing with solvent (high-flash naphtha or chloric solvent for example) if it is incompatible with the materials to be used.

08. DISASSEMBLY

First, **carry out the depressurization procedure** to avoid risks of serious injuries : spatters especially in eyes or injections under the skin can cause a blood poisoning when using such material. Then, unscrew the inlet and outlet fittings, disconnect the regulator air supply and put aside the regulator.

The maintenance consists in checking the seals and diaphragms as well as the parts of the regulator following leakages or only for a preventive maintenance.

We advice you to change the worn parts.

A. CHANGING THE DIAPHRAGMS

- Unscrew the 8 screws (25),
- Take off the cover (1),
- Take off, check and change if necessary the first diaphragm (6),
- Remove the first spacer assembly, then the second diaphragm, the second spacer assembly and so on...

B. CHANGING THE STOP SEALS

- Unscrew the 8 screws (25),
- Take off the cover (1),
- Take off, check and change if necessary the first diaphragm (6),
- Remove the first spacer assembly, then the second diaphragm, the second spacer assembly and so on...
- Unscrew the screws (5),
- Remove the plates (7),
- Take off the stops (4), change them if necessary,
- Take off, check and change if necessary the O Rings (3),
- Remove the pins (26),
- Put aside the spacers (2).

C. DISASSEMBLY OF THE CARTRIDGE

- Unscrew the 4 screws (19),
- Remove the cartridge (20).

D. CHANGING THE PUSH ROD AND THE VALVE GUIDE SEALS

- Unscrew the 4 screws (21),
- Remove the inlet block (18),
- Unscrew the 2 plugs (13),
- Remove the pin (15),
- Unscrew the screw (5),
- Take off the plate (7),
- Unscrew the 4 screws (22),
- Take off the valve guide assembly,
- Take off and check the seals (11 & 12), change them if necessary. The seal (12) must be changed each time you carry out the assembly.
- Take off the push rod (17),
- Remove the valve guide (10), the ball bearing (9) and the valve rod (16). The push rod (17) and the valve rod (16) must be assembled with Loctite 243 glue or similar,
- Remove the body (8).

09. ASSEMBLY

Carry out the assembly in the reverse order of the disassembly and comply with the instructions above.

10. MAINTENANCE

When using abrasive material, we advise you to carry out a systematic maintenance after a given working time. It is specified by the user maintenance staff and depends on the material, the working rate and the pressure.

The maintenance consists of :

- Check the seals and the tightness rings,
- Change if necessary the damaged parts,
- Lubricate the parts submitted to frictions,
- Check the parts do not have scratches,
- Clean carefully the parts without using metal parts or abrasive materials,
- Check the condition of seals.

IMPORTANT : Make sure during the assembly that the seals are not damaged to avoid a bad operating of the regulator.

11. TROUBLESHOOTING CHART

TROUBLES	CAUSES	SOLUTIONS
No regulation	Seat worn Impurity on the seat Mechanic assembly locked in low position Spring broken	Change the seat. Clean the seat. Remove, clean and check the mechanic assembly. Change the spring
No outlet pressure	No piloting air Push rod broken	Check the air circuit upstream. Change the push rod.
Bad regulation	Pressure or feeding flow rate too low Ball cage defective	Increase the pressure on the pump motor. Change the ball cage.
Pressure too low at the outlet	Piloting pressure too low Hole (s) in the diaphragm (s)	Increase the piloting pressure. Change the diaphragm (s).
Air leakage	Hole (s) in the diaphragm (s) The spacers are not tightened correctly. Stop seals worn or damaged.	Change the diaphragm (s). Tighten the spacers. Change the stop seals.
Material leakage	Valve guide seal (s) worn	Change the seal (s).