

Doc. 573.507.040

Modif. /Änderung : # ind. 22

Pièces de rechange

Date/Datum/Fecha : 14/12/04

Spare parts list

Annule/Cancel/

Ersatzteilliste

Ersetzt/Anula : 24/06/04

Piezas de repuesto

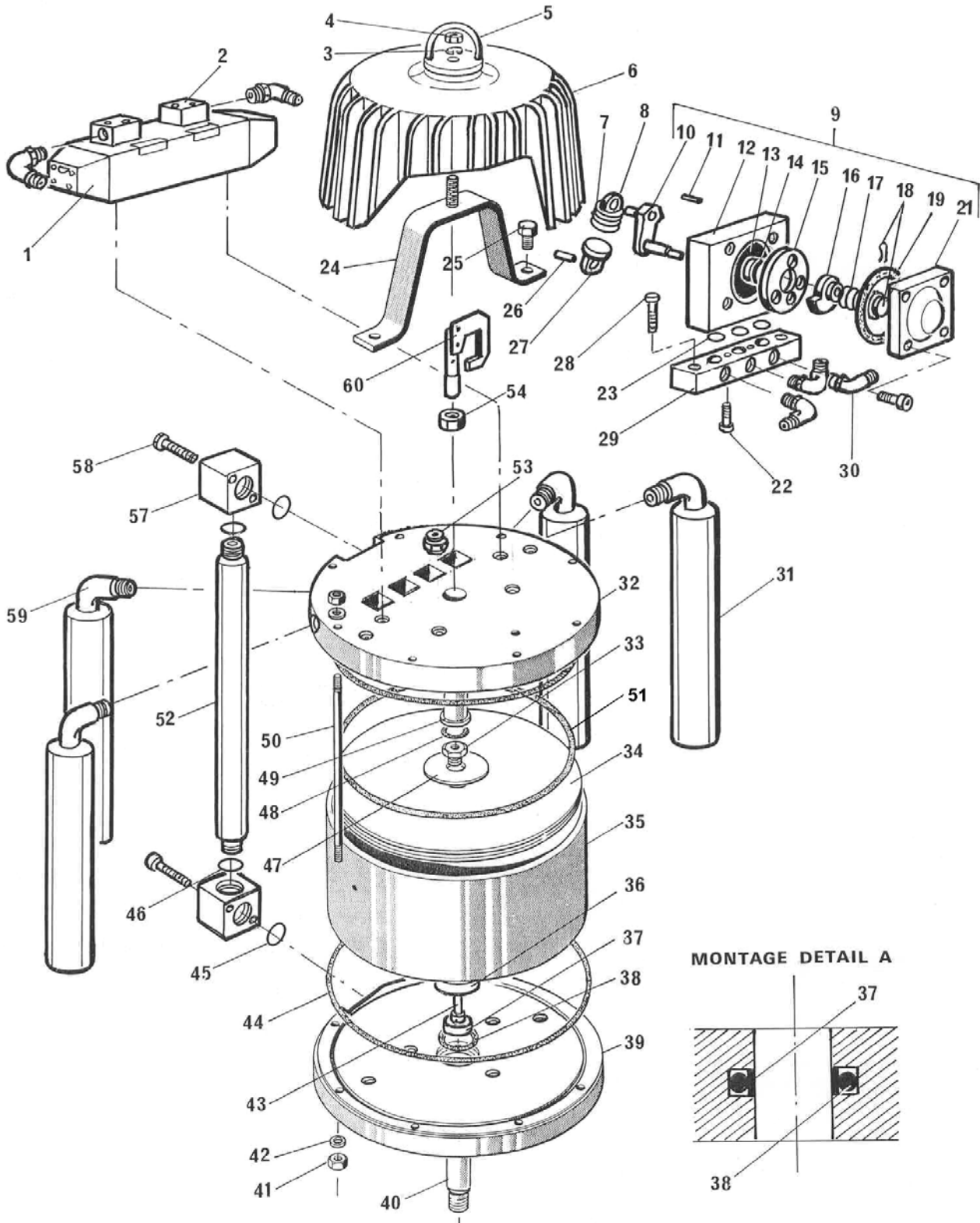

<b>MOTEUR A AIR, modèle 8000-6</b>	<b>AIR MOTOR, model 8000-6</b>	<b>#</b> <b>046.250.000</b>
<b>LUFTMOTOR, Modell 8000-6</b>	<b>MOTOR DE AIRE, tipo 8000-6</b>	

Ind	#	Désignation	Description	Bezeichnung	Denominación	Qté
1	903.050.483	Distributeur	Distributor	Luftverteiler	Distribuidor	1
2	046.250.009	Embase pilote	Base, distributor	Steuerblock	Base piloto	2
3	963.200.023	Rondelle WZ 12	Washer, WZ 12	Scheibe Ø 12	Arandela WZ 12	1
4	953.010.023	Ecrou HM 12	Nut, HM 12	Mutter M 12	Tuerca HM 12	1
5	046.170.200	Anneau de levage	Ring, cover	Öse	Anillo de leva	1
6	046.250.012	Cloche	Cover	Haube	Campana	1
7	146.199.902	Ressort (pochette de 10)	Spring (pack of 10)	Feder (Satz à 10 St.)	Muelle (bolsa de 10)	1
8	044.570.206	Chape mâle	Linkage, male	Federhalterung, männlich	Tapa macho	1
<b>*9</b>	<b>044.630.400</b>	<b>Bloc inverseur (rep. 10 à 23) (voir Doc. 573.087.040)</b>	<b>Reversing block (ind. 10 to 23) (refer to Doc. 573.087.040)</b>	<b>Umsteuerblock (Pos. 10-23) (siehe Dok. 573.087.040)</b>	<b>Bloque inversor (ind. 10 a 23) (consultar Doc. 573.087.040)</b>	<b>1</b>
22	933.151.277	Vis CHc M 6 x 20	Screw, CHc M 6 x 20	Schraube M 6 x 20	Tornillo CHc M 6 x 20	2
24	046.250.011	Pont de fixation	Bracket	Befestigungsbügel	Puente de fijación	1
25	933.011.394	Vis HM 12 x 30	Screw, HM 12 x 30	Schraube, HM 12 x 30	Tornillo HM 12 x 30	2
26	044.570.202	Axe de chape	Pivot pin, link	Achse für Federhalterung	Eje de tapa	1
27	044.570.131	Chape femelle	Linkage, female	Federhalterung, weiblich	Tapa hembra	1
28	933.011.390	Vis HM 8 x 30	Screw, HM 8 x 30	Schraube, HM 8 x 30	Tornillo HM 8 x 30	2
29	046.250.008	Embase inverseur	Base, reversing block	Grundplatte	Base inversor	1
30	905.120.902	Coude M 1/8 -T6	Elbow, M 1/8 -T6	Winkel, 1/8"	Codo M 1/8 -T6	5
31	046.250.015	Silencieux	Muffler	Schalldämpfer	Silenciador	4
32	046.250.001	Fond supérieur	Support, upper	Zylinderdeckel	Fondo superior	1
33	046.250.007	Ecrou piston	Nut, piston	Kolbenschraube	Tuerca pistón	1
34	046.250.003	Piston	Piston	Kolben	Pistón	1
35	046.250.021	Cylindre	Cylinder	Zylinder	Cilindro	1
36	046.250.004	Rondelle d'appui inférieur	Seal ring, lower	Untere Kolbenscheibe	Arandela de apoyo inferior	1
39	046.250.002	Fond inférieur	Support, lower	Zylinderboden	Fondo inferior	1
37	046.250.010	▪ Bague de frottement	▪ Ring	▪ Führungsbuchse	▪ Anillo de deslizamiento	1
38	909.420.109	▪ Joint torique	▪ O-Ring	▪ O-Ring	▪ Junta tórica	1
40	046.250.022	Tige moteur	Rod, piston	Kolbenstange	Eje motor	1
41	953.010.021	Ecrou HM 10	Nut, HM 10	Mutter HM 10	Tuerca HM 10	16
42	963.040.021	Rondelle MN 10	Washer, MN 10	Scheibe MN 10	Arandela MN 10	8

Ind	#	Désignation	Description	Bezeichnung	Denominación	Qté
43	046.250.023	Tige de pilotage	Rod, driving	Steuerstange	Eje de pilotaje	1
44	050.068.303	Joint de cylindre	Seal, cylinder	O-Ring, Zylinder	Junta de cilindro	2
45	909.130.521	Bague R 19	Ring, R 19	O-Ring, R 19	Anillo R 19	2
46	909.420.225	Joint	O-Ring	O-Ring	Junta	2
47	046.210.007	Rondelle supérieure	Washer, upper	Obere Kolbenscheibe	Arandela superior	1
48	144.579.923	Bague R 8 bis (pochette de 10)	Ring, R 8 bis (package of 10)	O-Ring, R 8 (Satz à 10 St.)	Anillo R 8 bis (bolsa de 10)	1
49	046.210.011	Bague de guidage	Bushing, guide	Buchse	Anillo guía	1
50	046.250.024	Tirant moteur	Tie-rod, motor	Verbindungsbolzen	Tirante motor	8
51	909.130.482	Bague R 80	Ring, R 80	O-Ring, R 80	Anillo R 80	1
52	046.250.025	Tube de liaison	Rod, connecting	Verbindungsrohr	Tubo de unión	1
53	903.130.508	Raccord, régulateur de pression (air de pilotage ⇒ P = 4 bar)	Fitting, pressure regulator (Piloting air ⇒ P = 4 bar / 58 psi)	Druckreduzierventil (Steuerluft ⇒ D = 4 bar)	Racor, regulator de presión (Aire de pilotaje ⇒ P = 4 bar)	1
54	953.010.019	Contre écrou HM 8	Locknut, HM 8	Kontermutter, HM 8	Contra tuerca HM 8	1
57	046.250.014	Bride	Collector	Flansch	Brida	2
58	933.151.497	Vis CHc M 6 x 40	Screw, CHc M 6 x 40	Schraube M 6 x 40	Tornillo CHc M 6 x 40	4
59	904.133.035	Coude M 3/4"- F 1"1/4	Elbow, M 3/4" - F 1" 1/4	Winkelnippel, AG 3/4", IG x1" 1/4"	Codo M 3/4" - H 1" 1/4	4
60	046.250.005	Tige de commande montée	Fork assembly, control	Umsteuerhebel	Eje de mando montado	1
-	901.180.024	Cable de mise à la terre (Lg. 5 m)	Ground (Length 5 m / 16.5 ft)	Erdungskabel (Länge 5m)	Cable de puesta a tierra (5 m de largo)	1

*	<b>146.259.901</b>	<b>Pochette de joints (ind. 7, 37, 38, 44, 45, 46, 48, 51 + pochette de joints du bloc inverseur)</b>	<b>Package of seals (ind. 7, 37, 38, 44, 45, 46, 48, 51 + package of seals of the reversing block)</b>	<b>Dichtungskit (Pos. 7, 37, 38, 44, 45, 46, 48, 51 + Dichtungssatz für Umschaltblock)</b>	<b>Bolsa de juntas (ind. 7, 37, 38, 44, 45, 46, 48, 51 + bolsa de juntas del bloque inversor)</b>	<b>1</b>
*	<b>146.259.905</b>	<b>Pochette de maintenance (ind. 49 + pochette de joints moteur + ind. 3, 5, 7, 8, 13 de l'inverseur)</b>	<b>Servicing kit (ind. 49 + package of seals of the air motor + ind. 3, 5, 7, 8, 13 of the reversing block)</b>	<b>Servicekit (Pos. 49 + Dichtungssatz für Motor + Pos. 3, 5, 7, 8, 13 für Umschaltungsblock)</b>	<b>Bolsa de mantenimiento (ind. 49 + bolsa de juntas motor + ind. 3, 5, 7, 8, 13 del inversor)</b>	<b>1</b>

- \* Pièces de maintenance préconisées tenues en stock
- \* Preceding the index number denotes a suggested spare part.
- \* Bezeichnete Teile sind empfohlene Ersatzteile.
- \* Piezas de mantenimiento preventivo a tener en stock.