



INSTRUCTION MANUAL
PILOTED REGULATOR FOR THICK FLUIDS
LARGE MODEL

Manual P.N° : 1202 573.141.112

TRANSLATION OF THE ORIGINAL MANUAL

Date : 27/02/12 - Supersede : 21/09/10 Modif. : Update

Dear Customer,

We thank you very much for purchasing an accessory from KREMLIN range.

To get the best result, safe and efficient operation of your manual fluid regulator, we advice you to read and make yourself familiar with the instruction and service manual.

1. SAFETY INSTRUCTIONS

- ➔ The personnel involved in operating and servicing this equipment must be aware of all safety requirements stated in this manual. The workshop supervisor must be certain that the personnel has perfectly understood the safety instructions and complies with them.
- ➔ Use the equipment only in a properly ventilated area to maximize health care. Any misuse of the spray equipment or accessories can damage them and result in serious body injury, fire or explosion hazard.
- ➔ This equipment is installed on installations operating under very high pressures. Check the pressure of the fluid supplied upstream of the regulator.
- ➔ All fittings must be tight and in good conditions.
- ➔ Before cleaning or removing components of the equipment :
 - stop the pump by shutting off the compressed air supply,
 - open the drain valve,
 - point the spray gun into an appropriate waste receptacle and press the trigger to depressurize the system.

KREMLIN - REXSON

150, avenue de Stalingrad

93 245 - STAINS CEDEX – France

☎ : 33 (0)1 49 40 25 25 Fax : 33 (0)1 48 26 07 16

www.kremlin-rexson.com

2. TECHNICAL FEATURES

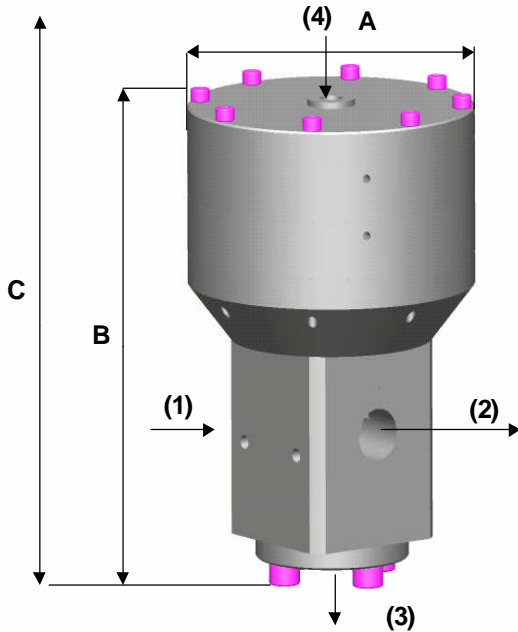

The regulator is used on installations that handle thick fluids (cold or hot).

The fluid pressure adjustment at the outlet of the regulator is carried out by adjusting the pilot air pressure.

To get a better adjustment of the piloted regulator, a precision air regulator drives the pilot air.

Various versions of the large model regulator are available :

- cold version : 80 bar / 1160 psi, 160 bar / 2320 psi, 240 bar / 3480 psi (these pressures indicate the maximum fluid pressure at the outlet of the regulator). You can change the version by adding or removing 1 or 2 stages on the regulator.

Regulator GM 80 bar / 1160 psi → 1 stage
 Regulator GM 160 bar / 2320 psi → 2 stages
 Regulator GM 240 bar / 3480 psi → 3 stages

- hot version : add an heating element supplied with 24 or 220V to the cold regulators.

The drain outlet, at the bottom, is closed by a plug.

Kind of regulator	GM 80 bar / 1160 psi	GM 160 bar / 2320 psi	GM 240 bar / 3480 psi
Dimensions : - A - B (regulator without pilot) - C (regulator with pilot)	Ø 150 mm / 5.90" 160 mm / 6.30" 276 mm / 10.90"	Ø 150 mm / 5.90" 190 mm / 7.50" 306 mm / 12.04"	Ø 150 mm / 5.90" 215 mm / 8.50" 331 mm / 13"
Weight : - Regulator without pilot - Regulator with pilot	6 kg / 13.224 lb 6,5 kg / 14.326 lb	7 kg / 15.428 lb 7,5 kg / 16.53 lb	8 kg / 17.632 lb 8,5 kg / 18.734 lb
Fittings : - Fluid inlet (1) - Fluid outlet (2) - Drain outlet or gauge (3) - Pilot air (4)	F 3/4 BSP F 3/4 BSP F 1/2 BSP F 1/4 BSP	F 3/4 BSP F 3/4 BSP F 1/2 BSP F 1/4 BSP	F 3/4 BSP F 3/4 BSP F 1/2 BSP F 1/4 BSP
Pressure range - Inlet - Use range (outlet) Pilot air pressure	30 to 180 bar max. /435 to 2610 psi max. 10 to 80 bar max. /145 to 1160 psi 6 bar max. / 87 psi max.	200 to 300 bar max. /2900 to 4350 psi max. 10 to 160 bar max. /145 to 2320 psi max. 6 bar max. / 87 psi max.	260 to 300 bar max. /3770 to 4350 psi max. 10 to 240 bar max. /145 to 3480 psi max. 6 bar max. / 87 psi max.
Wetted parts	Treated steel Stainless steel Carbide PTFE Polyethylene	Treated steel Stainless steel Carbide PTFE Polyethylene	Treated steel Stainless steel Carbide PTFE Polyethylene
Fluid maximum temperature	100°C / 212°F	100°C / 212 °F	100°C / 212 °F

3. TROUBLESHOOTING CHART

TROUBLE	CAUSE	SOLUTION
Overpressure at the regulator outlet.	Too important pilot air pressure. Improper proofness between seat and ball. Too important fluid pressure upstream of the regulator	Reduce the pilot pressure. Clean or replace. Reduce the pressure at the supply pump.
No fluid at the outlet of the regulator.	Insufficient pilot air pressure. Ball blocked on the seat.	Increase pilot air pressure. Clean and reinstall.
Irregular flow.	Too important pulsation in the fluid network. Improper proofness of seat and ball.	Check the network. Clean and replace.
Material leakage at the diaphragm case of the regulator	Defective GT seal.	Replace it.

4. REMOVAL

■ REPLACEMENT OF THE PIN WITH BALL (9) AND OF THE SEAT ASSEMBLY (12)

Unscrew the 4 screws (4).

Remove the lower body (2).

Unscrew the 2 screws (7) and remove the lower flange (10).

Unscrew the nut (11) and remove the pin with ball (9).

Unscrew the seat assembly (12).

Clean the parts with white spirit or with the appropriate cleaning solvent. Change them if necessary.

Change the ring (13) and the seal (5).

Remount the assembly in reverse order.

■ REPLACEMENT OF THE DIAPHRAGM (22) AND OF THE PISTON GT SEAL (16)

Removal :

Unscrew the 8 screws (24) and remove the cover (23).

Remove the stages(s) (25) (according the version of the regulator).

Put aside the diaphragm (22).

Unscrew the screw (21), then remove the pilot piston (20).

Extract the spring (19), unscrew the 4 screws (18) and remove the diaphragm housing (17) that gives access to the GT seal (16).

Reassembly :

Clean the parts with white spirit or change them if necessary.

Grease the seal (refer to drawing above)

Change the seal (5) situated on the piston.

Place the GT seal (16), lips towards the bottom, in its housing, inside the diaphragm housing (17).

GT seal (16) →

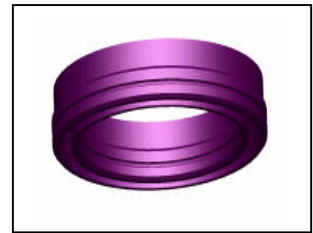

Fix the diaphragm housing (17), the intermediate body (15) and the body (1) via the 4 screws (18).

Place the diaphragm (19), the pilot piston (20) and fasten the screw (21).

Change the diaphragm(s) (28), if necessary.

Place the diaphragms, red side above.

Remount the parts corresponding to the pilot stages.

CAUTION : Line up the hole $\varnothing 5 / \varnothing 3/16$ on the diaphragms with those of the pilot stages.

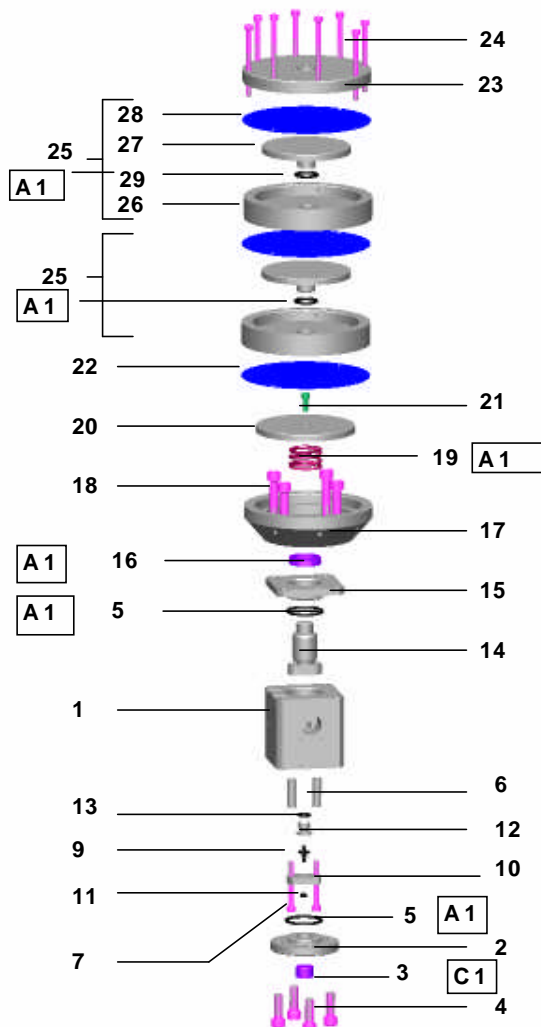

Index	Instructions
A 1	PTFE grease
C 1	High strength Aneorobic Pipe Sealant Loctite 577