

<p>Doc. 573.121.050 Date/Datum/Fecha : 12/03/12 Annule/Cancela/ Ersetzt/Anula : 26/08/08</p>	<p>Modif. /Änderung : Mise à jour / Update / Aktualisierung / Actualización</p>	<p>Pièces de rechange Spare parts list Ersatzteilliste Piezas de repuesto</p>
--------------------------------------------------------------------------------------------------------------------	--------------------------------------------------------------------------------------------------	--------------------------------------------------------------------------------------------------------------------------

<p>POMPE FLOWMAX®, modèle 40-25 F</p>	<p>FLOWMAX® PUMP, model 40-25 F</p>
<p>FLOWMAX® PUMPE, Modell 40-25 F</p>	<p>BOMBA FLOWMAX®, tipo 40-25 F</p>

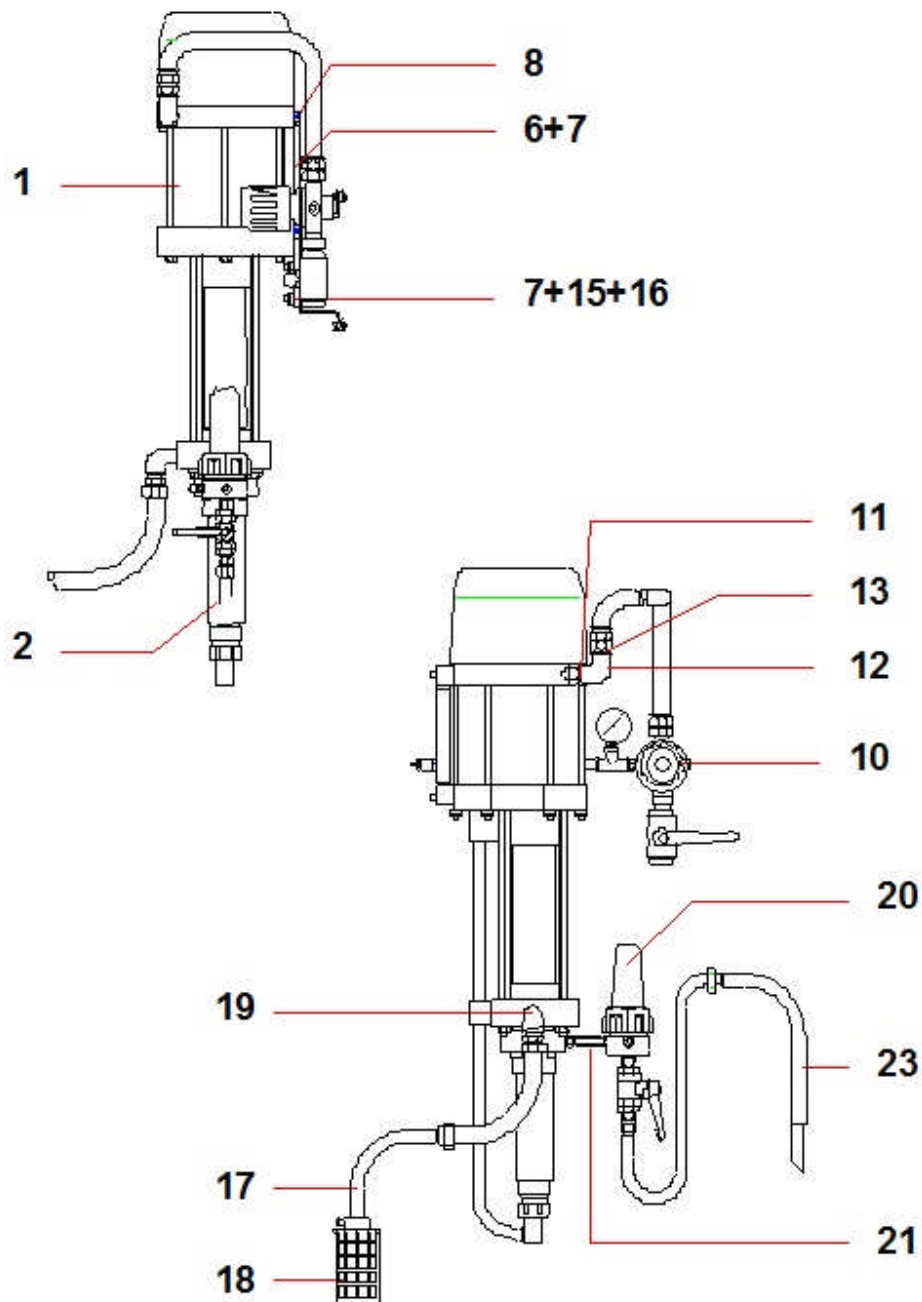

POMPE MURALE, modèle 40-25 F sans filtre	WALL MOUNTED PUMP, model 40-25 F without filter	# 151.776.100
WANDANLAGE, Modell 40-25 F ohne Filter	BOMBA MURAL, tipo 40-25 F sin filtro	

Ind	#	Désignation	Description	Bezeichnung	Denominación	Qté
-	151.776.000	Pompe 40.25 F nue	Bare pump, model 40.25 F	Pumpe 40.25 F, nackt	Bomba sola, tipo 40.25 F	1
* 1	146.275.000	▪ Moteur 1000-4 (voir Doc. 573.045.050)	▪ Air motor, model 1000-4 (refer to Doc. 573.045.050)	▪ Luftmotor 1000-4 (siehe Dok. 573.045.050)	▪ Motor, tipo 1000-4 (consultar Doc. 573 045 050)	1
* 2	144.950.200	▪ Hydraulique FLOWMAX 25 F (voir Doc. 573.115.050)	▪ Fluid section, model FLOWMAX 25 F (refer to Doc. 573.115.050)	▪ FLOWMAX Hydraulikteil 25 F (siehe Dok. 573.115.050)	▪ Hidráulica FLOWMAX 25 F (consultar Doc. 573.115.050)	1
6	051.770.101	Plaque d'interface	Plate	Befestigungsplatte	Placa	1
7	933.011.279	Vis M 8 x 20	Screw, M 8 x 20	Schraube M 8 x 20	Tornillo, M 8 x 20	3
8	933.151.147	Vis CHc - M 8 x 10	Screw, CHc - M 8 x 10	Schraube CHc M 8 x10	Tornillo CHc - M 8 x 10	1
10	151.790.160	Equipement d'air (voir Doc. 573.403.050)	Air supply (refer to Doc. 573.403.050)	Luftausrüstung (siehe Dok. 573.403.050)	Equipo de aire (consultar Doc. 573.403.050)	1
11	904.523.006	Raccord, M 3/8 BSP - M 1/2 BSP	Fitting, double male, 3/8 BSP - 1/2 BSP	Doppelnippel AG 3/8 BSP - 1/2 BSP	Racor, M 3/8 BSP - M 1/2 BSP	1
12	904.123.004	Coude FF 1/2	Elbow, FF 1/2	Winkelnippel IG 1/2	Codo, HH 1/2	1
13	050.102.401	Raccord, M 1/2 BSP - M 3/4 NPS	Fitting, double male, 1/2 BSP - 3/4 NPS	Doppelnippel AG 1/2 BSP - 3/4 NPS	Racor, M 1/2 BSP - M 3/4 NPS	1
15	963.040.019	Rondelle MN 8	Washer, MN 8	Scheibe MN 8	Arandela, MN 8	2
16	953.010.019	Ecrou HM 8	Nut, HM 8	Mutter HM 8	Tuerca, HM 8	2
17	049.596.110	Canne d'aspiration inox avec crépine	Suction rod (stainless steel) with strainer	Saugschlauch (Edelstahl) mit Siebkorb	Caña de aspiración inox con piña	1
18	149.591.400	▪ Crépine avec manchon	▪ Strainer with sleeve	▪ Siebkorb	▪ Piña con manguito	1
19	050.102.437	Raccord inox M 1/2 BSP - M 26 x 125	Fitting, stainless steel, double male, 1/2 BSP - 26 x 125	Doppelnippel Edelstahl AG 1/2 BSP - M 26 x 1,25	Racor inox M 1/2 BSP - M 26 x 125	1

* Pièces de maintenance préconisées tenues en stock

* Preceding the index number denotes a suggested spare part.

* Bezeichnete Teile sind empfohlene Ersatzteile.

* Piezas de mantenimiento preventivas a tener en stock.

POMPE MURALE, modèle 40-25 F avec filtre	WALL MOUNTED PUMP, model 40-25 F with filter	# 151.776.200
WANDANLAGE , Modell 40-25 F mit Filter	BOMBA MURAL, tipo 40-25 F con filtro	

Ind	#	Désignation	Description	Bezeichnung	Denominación	Qté
-	151.776.100	Pompe murale sans filtre	Wall mounted pump without filter	Wandpumpe ohne Filter	Bomba mural sin filtro	1
20	155.580.400	Filtre AIRLESS® inox 3/8 (voir Doc. 573.299.050)	AIRLESS filter 3/8, stainless steel (refer to Doc. 573.299.050)	AIRLESS® Filter 3/8, Edelstahl (Siehe Dok. 573.299.050)	Filtro AIRLESS® inox 3/8 (consultar Doc. 573.299.050)	1
21	055.580.301	Manchon inox MM 3/8 NPT	Sleeve, stainless steel MM 3/8 NPT	Muff Edelstahl AG 3/8 NPT	Manguito inox MM 3/8 NPT	1
23	049.596.000	Canne de purge inox	Drain rod, stainless steel	Entleerungsrohr, Edelstahl	Caña de purga inox	1

POMPE 40-25 F SUR CHARIOT	CART MOUNTED PUMP, model 40-25 F	# 151.776.400
PUMPE 40-25 F FAHRBAR	BOMBA 40-25 F SOBRE CARRETILLA	

Ind	#	Désignation	Description	Bezeichnung	Denominación	Qté
-	151.776.200	Pompe murale avec filtre	Wall mounted pump with filter	Wandpumpe mit Filter	Bomba mural con filtro	1
-	051.221.000	Chariot (2 bras)	Cart (2 arms)	Fahrgestell (2 Arme)	Carretilla (2 brazos)	1
-	056.100.199	Panneau de fixation	Wall bracket unit	Wandplatte	Soporte de fijación	1

Nota : Dans le cas d'une pompe nue pour fixation murale, commander la pompe nue , la plaque d'interface (ind.6) et le support réf. 044.910.121 (rep. 1 - Doc. 573.403.050)

Nota : For a bare pump with wall bracket, order bare pump, plate (ind. 6) and bracket – P.N°. 044.910.121 (ind. 1 - Doc. 573.403.050)

Hinweiss : Für eine nackte Pumpe mit Wandhalterung, bestellen Sie die nackte Pumpe, die Umsteuerplatte (Pos. 6) und die Halterung Bestell-Nr. 044.910.121 (Pos. 1 - Dok. 573.403.050)

Nota : En caso de una bomba sola con fijación mural, encargue Vd. la bomba sola, la placa (ind. 6) y el soporte con la referencia 044.910.121 (ind. 1 - Doc. 573.403.050).

		OPTION	OPTIONAL	OPTION	OPCIÓN	
-	151.740.200	Kit air de pulvérisation (voir Doc. 573.035.050)	Atomizing air kit (refer to Doc.573.035.050)	Zerstäuberluftset (siehe Dok. 573.035.050)	Kit aire de pulverización (consultar Doc. 573.035.050)	1