

SPECIFICATIONS

AIRMIX[®] GUN

- MODEL MVX

with SFX swivel fitting

Manual : 0902 573.074.212

Date : 17/02/09

Supersede :

Modif. :

ADDITIONAL DOCUMENTATIONS

SPARE PARTS : MVX GUN (Doc. 573.393.050)

KREMLIN REXSON - 150, avenue de Stalingrad
93 245 - STAINS CEDEX - FRANCE
Téléphone : 33 (0)1 49 40 25 25 Fax : 33 (0)1 48 26 07 16

Note : For HVLP compliance, the maximum inlet air pressure at the gun handle must not exceed 12.68 psi (0,87bar) to maintain 10 psi (0,68 bar) or less at the air cap. Testing for HVLP compliance was performed using the specified HVLP test air cap, the fan control fully closed and a pressure gauge on the air inlet fitting at the gun handle. It may also be a requirement of some regulatory agencies that users have the appropriate test air cap available on site to verify that the gun is being operated within the regulatory limitations.

Assembly : Remove the cap located at the end of the fluid tube and install a swivel fitting instead of it. Tighten the fitting with the wrench.

A fitting is supplied with the gun. Install a fitting at the outlet of the gun air regulator. Connect the gun air hose on that fitting.

▪ **FAN WIDTHS WITH VX14 AIR CAP**

Aircap with 2 pins and + tip with 2 mating recesses



NOZZLES	Pp = 35 bar / 507.5 p.s.i		Pp = 70 bar / 1015 p.s.i	
	L 1 (cm / ")	L 2 (cm / ")	L 1 (cm / ")	L 2 (cm / ")
04/094	20 / 7.87	7 / 2.75	20 / 7.87	9 / 4.33
04/114	22 / 8.66	7 / 2.75	23 / 9.05	9 / 4.33
06/094	21 / 8.26	8 / 3.15	21 / 8.26	10 / 3.93
06/114	23 / 9.05	8 / 3.15	23 / 9.05	12 / 4.72
06/134	25 / 9.84	10 / 3.93	27 / 10.63	14 / 5.51
06/154	28 / 11.02	11 / 4.33	31 / 12.20	17 / 6.7
09/094	21 / 8.26	9 / 4.33	23 / 9.05	10 / 3.93
09/114	21 / 8.26	8 / 3.15	23 / 9.05	12 / 4.72
09/134	28 / 11.02	10 / 3.93	30 / 11.81	14 / 5.51
09/154	28 / 11.02	12 / 4.72	29 / 11.41	16 / 6.3
12/094	21 / 8.26	9 / 4.33	22 / 8.66	11 / 4.33
12/114	24 / 9.45	10 / 3.93	26 / 10.23	12 / 4.72
12/134	26 / 10.23	10 / 3.93	28 / 11.02	14 / 5.51
12/154	26 / 10.23	10 / 3.93	30 / 11.81	16 / 6.3
12/174	31 / 12.20	12 / 4.72	33 / 13	18 / 7.08
14/094	22 / 8.66	9 / 4.33	22 / 8.66	11 / 4.33
14/114	23 / 9.05	9 / 4.33	24 / 9.45	12 / 4.72
14/134	27 / 10.63	10 / 3.93	28 / 11.02	16 / 6.3
14/154	29 / 11.41	12 / 4.72	32 / 12.6	19 / 7.48
14/174	30 / 11.81	12 / 4.72	34 / 13.38	21 / 8.26
18/134	30 / 11.81	12 / 4.72	31 / 12.20	20 / 7.87
18/154	29 / 11.41	12 / 4.72	32 / 12.6	20 / 7.87
18/174	31 / 12.20	12 / 4.72	33 / 13	22 / 8.66

- L 1** : maximum fan width
(fan air control closed)
- L 2** : reduced fan width
(fan air control opened)

Pp : fluid pressure

Testing conditions :

Gun handle air pressure = 1,5 bar / 21.75 psi

Viscosity = 45 s (CA 4) or 120 mPas.s

Temperature : 20°C / 68° F

Distance between the gun and the surface to be painted : 20 cm / 7.9"

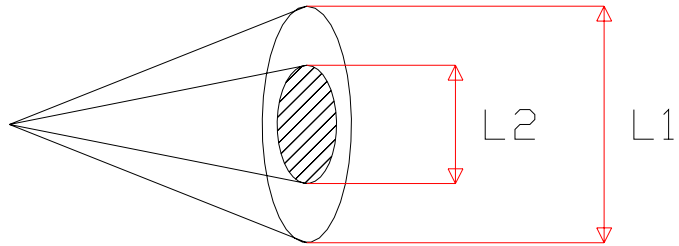

2. REMOVAL - REASSEMBLY



WARNING :

Before any action on the spray gun, shut off the compressed air supply and depressurize the systems by triggering the spray gun.

▪ **SEAT (64)**

Remove air cap, then unscrew seat-holder (63) by means of the wrench (72) supplied with the spray gun.

Clean the inside of the spray gun. If necessary, replace by a new assembly (refer to spare parts, ind. 62 & 64).

Loosen screw (66) by means of a screwdriver, take off the seat (64) and replace it.

Replace the seat as shown opposite (tightness cone towards the needle). Do not forget the seal of the seat (65) for the MVX 120 and MVX 200 spray guns.

Reassemble in reverse order.

➡ **Screw the seat-holder with the wrench provided by respecting the torque indicated at paragraph : "Assembly instructions".**

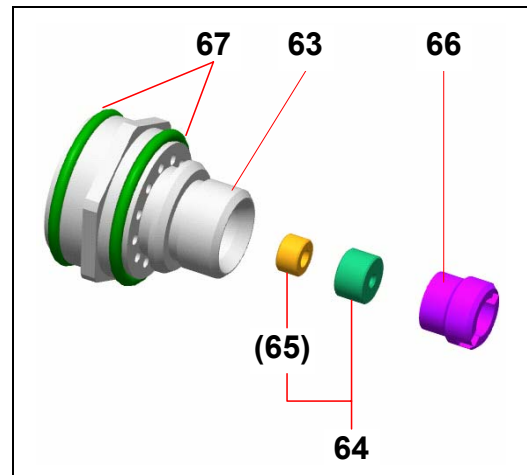

▪ **NEEDLE AND CARTRIDGE (20)**

Remove seat-holder (62) as indicated previously.

Remove trigger (53) by taking off the screw (55) and the spindle (54).

Remove pin packing (23).

Push needle frontwards while pushing the back part of the packing.

Push needle with packing out of body core.

If required, replace them (refer to spare parts).

Reassemble in reverse order.

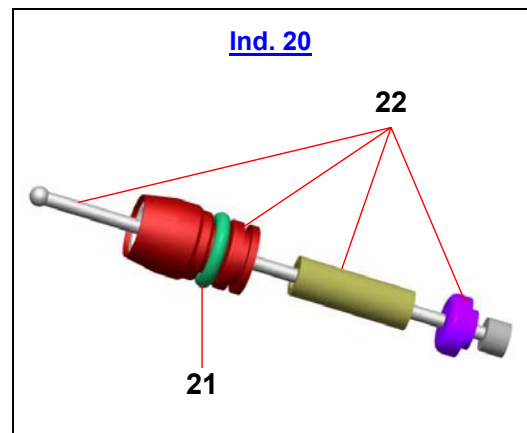

■ **AIR VALVE ASSEMBLY (25)**

Remove the gun trigger (53).

Remove the seat-holder (62).

Unscrew the sleeve (60) from the needle line.

Unscrew the needle spring (61), the needle strainer (33) and the needle rod (32).

Take off the air valve (25) by pushing it at the back of the spray gun.

Take care of spring valve (31).

If required, replace air valve assembly (refer to spare parts).

Reassemble first valve, trigger, needle rod, valve spring, needle strainer, needle spring, then sleeve.

➡ **Be careful with the orientation order of the needle rod. Assemble the smaller diameter to the needle line sleeve.**

■ **REPLACEMENT OF AIR VALVE SEAL (29)**

Remove air valve (25) - (refer to previous paragraph).

Take off the seal (29).

Place the new seal (29) in its housing.

Lubricate it.

When reassembling :

➡ **Carefully, insert the valve into the gun body carrying out a rotary motion so as to preformate the valve seal (29).**

Reassemble the other parts as previously indicated.

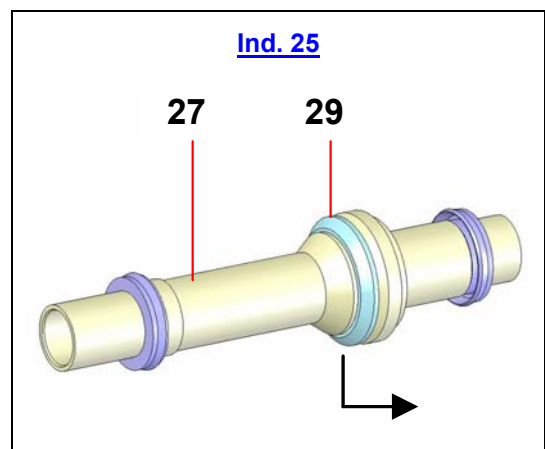

■ **REPLACEMENT OF SCREEN (49)**

Unscrew the swivel fitting (68) located at the gun handle.

Unscrew the screen support (49).

Make the filter slide (48), change it or clean it.

Change the seal (47).

Reassemble the parts in the reverse order of the disassembly sequence.

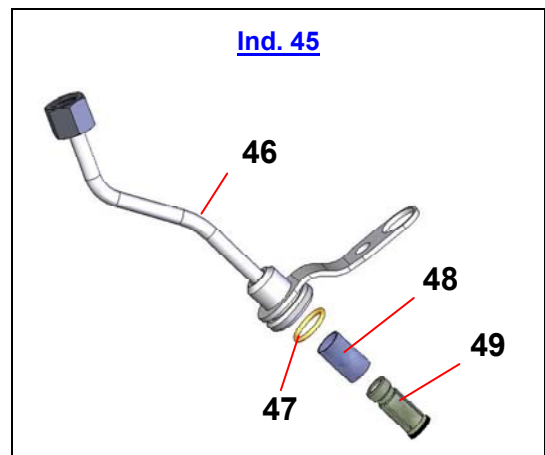

Before reassembling the different components :

- Clean the parts with the appropriate cleaning solvent with a brush.
- Install new seals after having lubricated them with PTFE grease.
- Install new parts if necessary.

3. ASSEMBLY INSTRUCTIONS

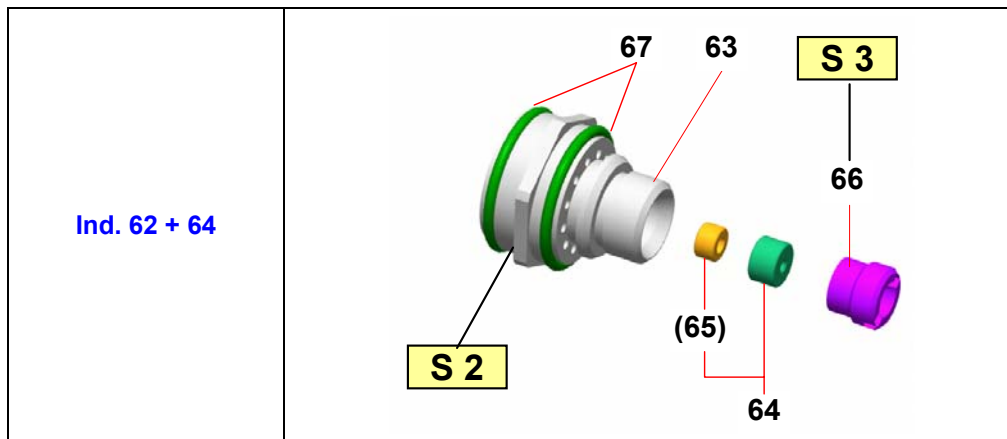
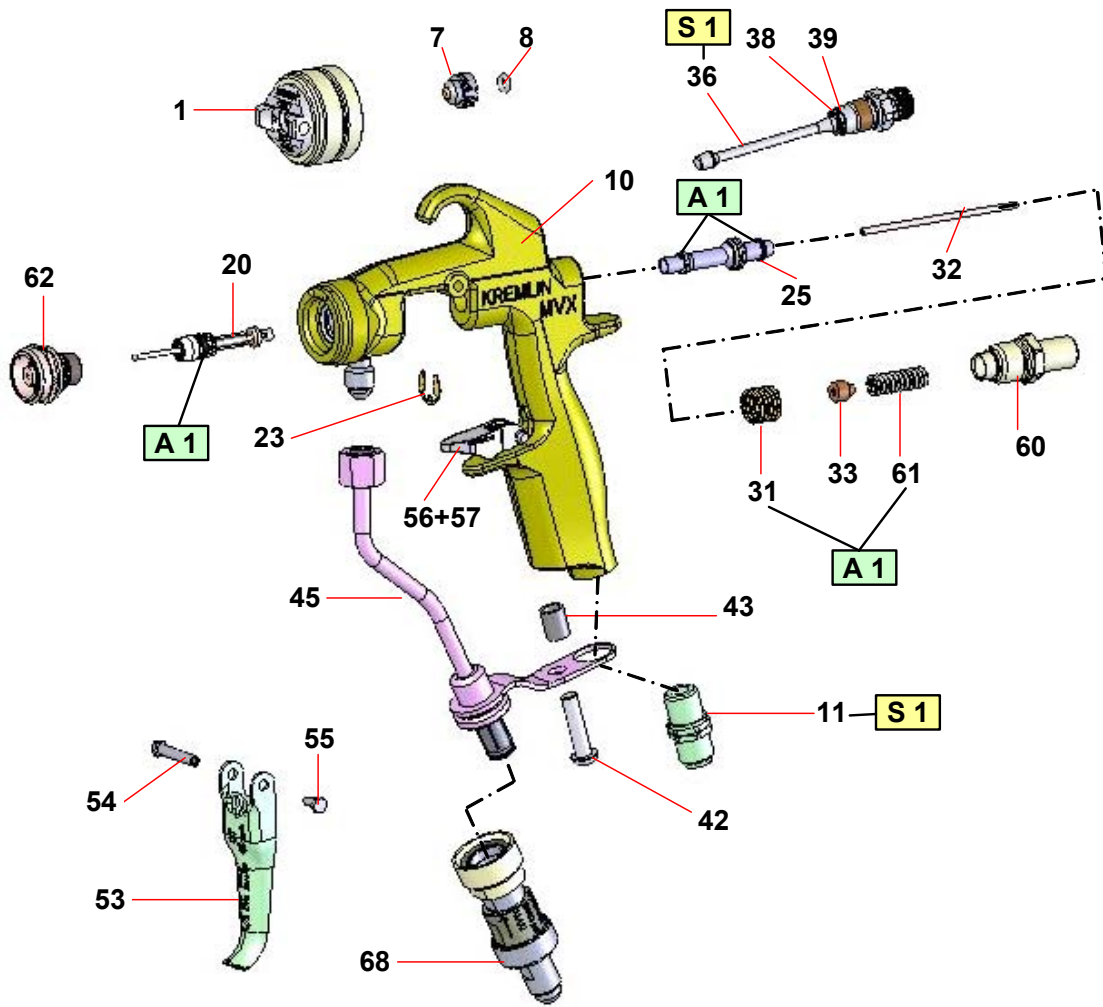

Index	Instructions	Description	Part number
A 1	PTFE Grease	"TECHNILUB" grease (10 ml)	560.440.101
S 1	Screwing torque :	9 - 11 Nm / 6.6 to 8.1 ft/lbf	
S 2	Screwing torque :	24 Nm / 17.7 ft/lbf	
S 3	Screwing torque :	2 Nm / 1.4 ft/lbf	