



INSTRUCTION MANUAL  
**EXTRUSION PUMP**

*Manual : 1004 573.004.212*

*Date : 9/04/10 - Annule/supersede : 10/03/04*

*Modif. Update*

**ORIGINAL MANUAL**

***IMPORTANT : before assembly and start-up, please read and clearly understand all documents relating to this equipment (professional use only).***

*PICTURES AND DRAWINGS ARE NON CONTRACTUAL. WE RESERVE THE RIGHT TO MAKE CHANGES WITHOUT PRIOR NOTICE.*

**KREMLIN - REXSON**

150, avenue de Stalingrad

93 245 - STAINS CEDEX – France

**☎ : 33 (0)1 49 40 25 25      Fax : 33 (0)1 48 26 07 16**

**[www.kremlin-rexson.com](http://www.kremlin-rexson.com)**



**INSTRUCTION MANUAL**  
**EXTRUSION PUMP**

**SUMMARY**

1. WARRANTY.....	2
2. SAFETY INSTRUCTIONS .....	3
3. DESCRIPTION .....	5
4. OPERATING PRINCIPLE .....	6
5. INSTALLATION .....	7
6. START UP.....	8
7. MAINTENANCE .....	10
8. TROUBLESHOOTING CHART .....	11

The specifications of the pump - features and maintenance - are available in a documentation enclosed to the manual.

Dear Customer,

We thank you very much for purchasing our new extrusion pump. You are the owner of one of the most reliable pumping system available on the market.

To make sure your investment will provide full satisfaction, special care has been taken during all designing and manufacturing processes.

To obtain the best result, safe and efficient operation of your equipment, we advice you to read and make yourself familiar with this instruction and service manual. Indeed, the non-compliance with instructions and precautions stated in this manual could reduce the equipment working-life, result in operating trouble and create unsafe conditions.

## 1. WARRANTY

We reserve the right to make changes; these changes may be carried out after the receipt of our order. No claim will be accepted as a consequence of any change carried out in the instruction manuals or in the selection guides.

Our equipment is checked and tested prior to shipment. In the case of a problem arising with the equipment, this must be in writing, within ten days from the delivery date.

KREMLIN REXSON warrants all equipment manufactured bearing its name, to be free from defect in material or workmanship for a period of 12 months (one shift per day or 1800 hours - 1 term reached) from the date of delivery. Work life is based on single shift working - 8 hours per day. Warranty claims for defective items will only be accepted in writing and will be verified and confirmed by us.

The warranty does not cover fair wear tear, damage or wear caused by misuse, improper maintenance or non-observance of our recommendations.

KREMLIN REXSON will repair or replace parts (carriage paid to our plant and accepted as defective by us). We shall not be liable for any losses, resulting from a production breakdown. Upon request, we can carry out service work at your premises; all expenses (travelling and accommodation) for KREMLIN REXSON technicians will be chargeable.

In the event that it is found that equipment has been tampered with, this will invalidate the warranty. Equipment that is bought in will be subject to the supplier's warranty.

## 2. SAFETY INSTRUCTIONS

### GENERAL SAFETY INSTRUCTIONS



**CAUTION :** The equipment can be dangerous if you do not follow our instructions concerning installation and servicing described in this manual and in accordance with applicable European standards and local national safety regulations.

Please carefully read all the instruction literature before operating your equipment.

**Only trained operators can use the equipment** (To acquire an essential training, please contact the "KREMLIN REXSON University" training center - Stains).

The foreman must ensure that the operator has understood the safety instructions for this equipment as well as the instructions in the manuals for the different parts and accessories.

Read carefully all instruction manuals, label markings before operating the equipment.



















Incorrect use may result in injury. This equipment is for professional use only. It must be used only for what it has been designed for. Never modify the equipment. The parts and accessories supplied must be regularly inspected. Defective or worn parts must be replaced.

**Guards (motor cover, coupling shields, connectors,...) have been designed for a safe use of the equipment.**  
**The manufacturer will not be held responsible for bodily injury or failure and / or property damage due to destruction, the overshadowing or the partial or total removal of the guards.**

**Never exceed the equipment components' maximum working pressure.**

Comply with regulations concerning safety, fire risks, electrical regulations in force in the country of final destination of the material. Use only products or solvent compatible with the parts in contact with the material (refer to data sheet of the material manufacturer).

### PICTOGRAMS

					
NIP HAZARD	WARNING MOVING ELEVATOR	WARNING MOVING PARTS	WARNING MOVING SHOVEL	DO NOT EXCEED THIS PRESSURE	HIGH PRESSURE HAZARD
					
RELIEF OR DRAIN VALVE	WARNING HOSE UNDER PRESSURE	WEAR GLASSES OBLIGATORY	WEAR OF GLOVES IS OBLIGATORY	PRODUCT VAPOR HAZARDS	WARNING HOT PARTS OR AREAS
					
ELECTRICAL HAZARD	WARNING FIRE HAZARDS	EXPLOSION HAZARDS	GROUNDING	WARNING (USER)	WARNING SERIOUS INJURIES

## FIRE - EXPLOSION - SPARKS - STATIC ELECTRICITY HAZARDS

A poor earth connection, inadequate ventilation, sparks or static electricity can cause an explosion or fire. To avoid these risks when using or servicing KREMLIN REXSON equipment, the following safety procedures must be followed :



- ensure a good earth connection and ground the parts to be handled i.e. solvents, materials, components and equipment,
- ensure adequate ventilation,
- keep working area clean and free from waste solvents, chemicals, or solid waste i.e. rags, paper and empty chemicals drums,
- never use electrical switches / power if in an atmosphere of volatile solvent vapour,
- stop working immediately in case of electrical arcs,
- never store chemicals and solvents in the working area.
- use paint whose flash point is the highest possible to prevent from any formation of gas and inflammable vapours (refer to materials' safety instructions),
- install a cover on the drums to reduce the diffusion of gas and vapours in the spray-booth.

## TOXIC PRODUCT HAZARDS

Toxic products or vapours can cause severe injury not only through contact with the body, but also if the products are ingested or inhaled. It is imperative :



- to know the material products and their risks,
- notified or hazardous materials must be stored in accordance with the regulations,
- the material must be stored in an appropriate container, never place materials in a container where there is a risk of spillage or leakage,
- a procedure must be applied for the safe disposal of waste material. It must comply with all prevailing regulations and legislations of the country where the equipment is to be used,
- protective clothing should always be worn in compliance with the material manufacturers' recommendations,
- depending on the application and chemical safety instructions, safety glasses, hearing protective earplug, gloves, foot wear, protective masks and possible breathing equipment should be worn to comply with the regulations (Refer to chapter "Safety equipment of KREMLIN selection guide).



### **CAUTION!**



It is forbidden to use material containing high concentrations of halogenated hydrocarbon solvents with **aluminium or zinc fillers**. Non-compliance with the instructions may cause explosion risk causing serious or fatal injury.

## EQUIPMENT REQUIREMENTS

**Guards (motor cover, coupling shields, connectors,...) have been designed for a safe use of the equipment.**  
**The manufacturer will not be held responsible for bodily injury or failure and / or property damage due to destruction, the overshadowing or the partial or total removal of the guards.**

### **PUMP**



Before carrying out any work, it is imperative to read and clearly understand the disassembly and reassembly instructions before servicing. The operator must understand the equipment and the safety instructions. These instructions are available in the equipment manuals.



The air motor is designed to be mounted with a pump. Never modify any components or couplings. When operating, please keep hands away from moving parts. Before starting up the equipment, please read the PRESSURE RELIEF instructions. Please ensure that any relief or drain valves fitted are in good working order.

### **HOSES**

- Keep hoses out of circulation areas, moving parts or hot surfaces,
- Never expose product hoses to temperature higher than + 60°C / 140° F or lower than 0°C / 32° F,
- Never pull or use the hoses to move the equipment,
- Tighten all fittings as well as the hoses before operating the equipment,
- Check the hoses regularly; change them if they are damaged,
- Never exceed the working pressure (WP) indicated on the hose.

## USED PRODUCTS

Considering the wide variety of products that are available and can be used in our equipment it is impossible to check and make recommendations for all chemical data, regarding the risks of possible chemical attack and their long term chemical reaction

KREMLIN REXSON can not be held liable for :

- Compatibility of wetted parts,
- Risks to staff and the surroundings,
- for worn or defective parts, for faulty equipment or units, or the quality of final product.

It is the responsibility of the user to know and prevent any possible risks such as toxic vapours, fires or explosions. He shall determine the risks of immediate reactions or pursuant to repeated exposures of the staff,

KREMLIN REXSON shall not be liable for physical injuries, direct or indirect material damages caused by the use of chemicals.

## **3. DESCRIPTION**

The extrusion pumps are designed to extrude thick or semi-thick materials (filler, paste filler, glues...) from a 30L or 60L or 200L drum (depending upon the model).

These pumps can be wall-mounted pumps or mounted on a double column elevator. The foot of the pump is equipped with a follower plate.

You can mount these pumps per two (in pairs) with drum changing automatic system.

These extrusion pumps are cold or hot extrusion pumps depending upon the models.

## 4. OPERATING PRINCIPLE

### ■ EXTRUSION PUMP WITH BALL FLUID SECTION

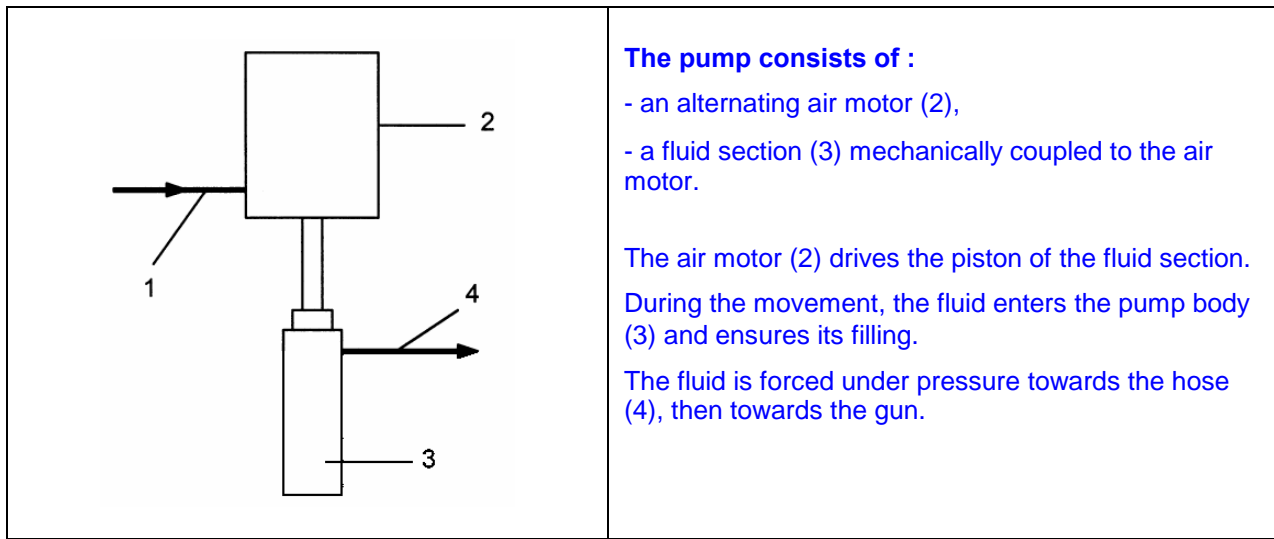

Due to its design, the pressure in (4) is always the pressure in (1) x ratio of the pump.



Ex : P (1) = 5 bar  
If ratio pump : 40  
P (4) = 5 x 40 = 200 bar

### ■ EXTRUSION PUMP WITH PALLET FLUID SECTION

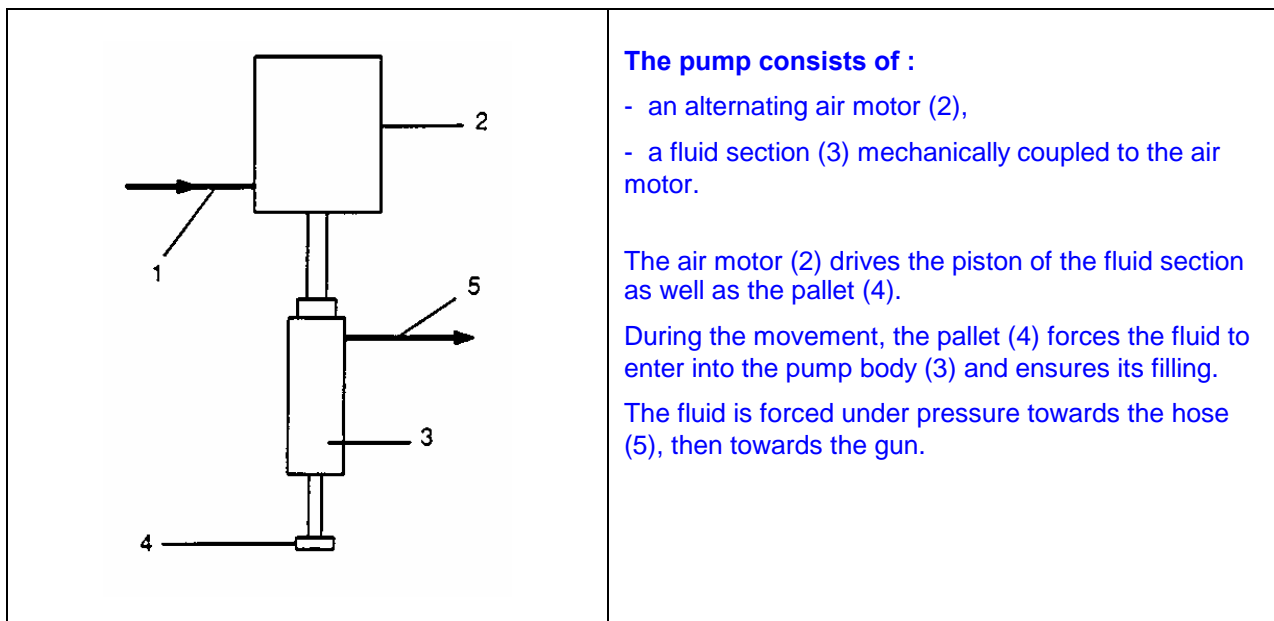

Due to its design, the pressure in (5) is always the pressure in (1) x ratio of the pump.



Ex : P (1) = 5 bar  
If ratio pump : 60  
P (5) = 5 x 60 = 300 bar

## 5. INSTALLATION

### Single pump on elevator

A "pump on elevator" equipment consists of :

- a pump (1)
- a double column elevator (2)
- a follower plate (3)  
(depending upon the drum Ø)
- an air supply (4)
- a fluid outlet (5)
- fittings (6)
- one or several manual or automatic spray guns (7).

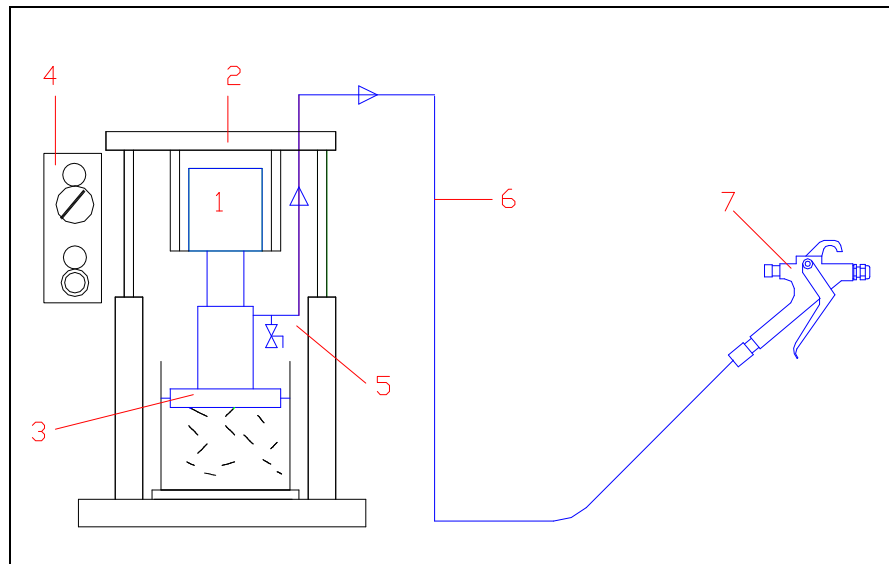

### Pumps in pairs (double group)

Mount 2 pumps on elevator, with a drum changing automatic system.

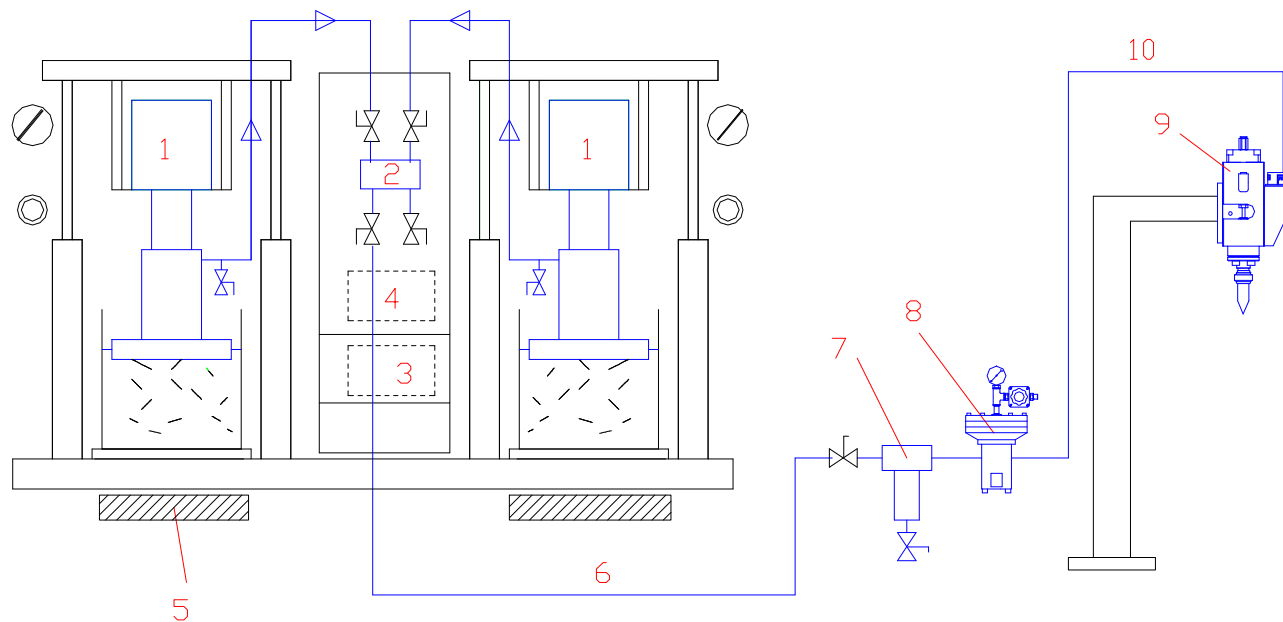

Ind.	Description
1	Pump on elevator
2	Collector
3	FR (Regulator filter)
4	IFA (Drum reversing)
5	Rolling table

Ind.	Description
6	HP network hose Ø 25 mm
7	HP filter
8	Fluid regulator
9	Manual or automatic gun
10	Flexible hose HP Ø 16 mm



## Dimensions

### DOUBLE GROUP

Maximum height : 3300 mm / 130"

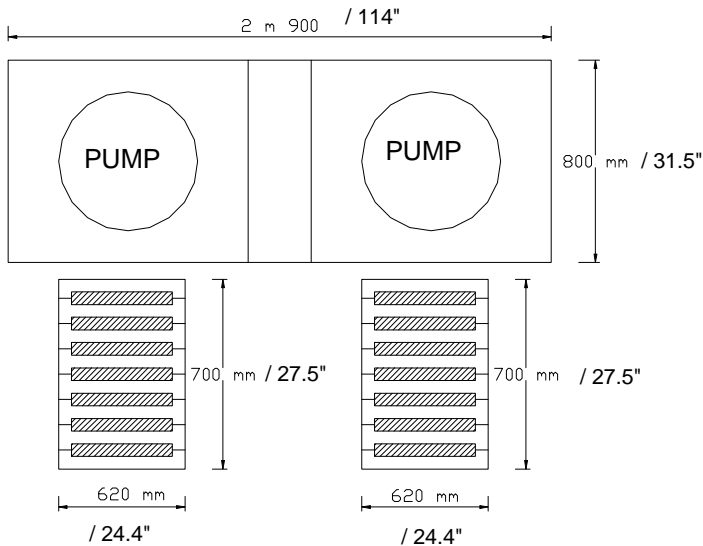

### SINGLE UNIT

Maximum height : 3300 mm / 130"

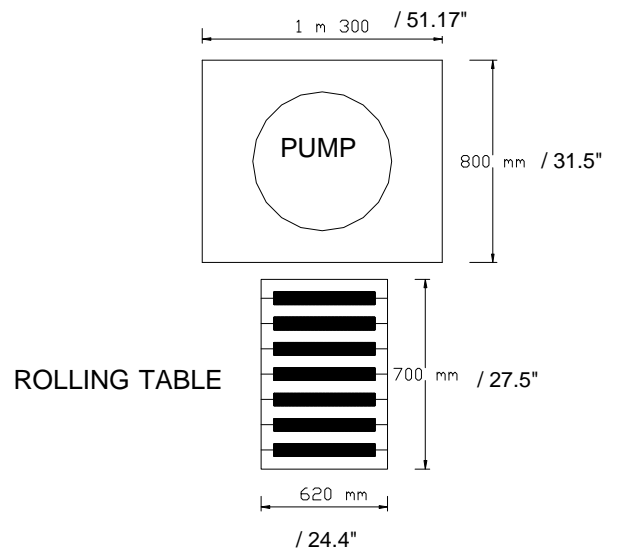

## Assembly and connection

Fill up the wetting-cup of the pump with T lubricant or with the appropriate solvent.

Connect the air equipment to the compressed air network (clean air, maximum 6 bar / 87 psi) by means of an hose (ID : 20 mm).

Connect all the hoses.

Unscrew the pneumatic adjustments regulators "MOTOR AIR" and "CYLINDER AIR" and "PILOTING AIR" (only for big motors).

Shut off the pump drain valve.

Place the handle of the distributor MA 1 horizontally.

Supply compressed air (6 bar /87 psi) to the installation.

## 6. START UP

### ■ PRIMING OF THE SINGLE PUMP

Screw the "PILOTING AIR" if there is one to give a pressure between 2.5 to 5 bar / 36 to 72.5 psi.

Open the drain valve.

Prime the pump screwing progressively the "MOTOR AIR" pneumatic regulator until the pump starts up.

Check the fluid flow at the pump outlet. When the fluid flows without bubble, shut off the drain valve.

Adjust the "MOTOR AIR" pneumatic regulator to obtain the required pressure and fluid flow.

### ■ PRIMING OF THE PUMP MOUNTED ON ELEVATOR, EQUIPPED WITH A FOLLOWER PLATE

Screw the "CYLINDER AIR" regulator.

Place the pump in upper position.

Remove the drain-cock placed in the plate.

Place the fluid drum.

Lower the pump and place the pump in contact with the material.

As soon as the fluid flows out from the drain, replace the drain-cock. If it does not flow out, increase the pressure (CYLINDER AIR regulator).

Screw the "PILOTING AIR" (if there is one) to give a pressure between 2.5 to 5 bar / 36 to 72.5 psi.  
Open the drain valve placed at the pump fluid outlet.  
Screw the "MOTOR AIR" regulator until the pump starts up.  
Check the fluid flow at the outlet of the pump.  
Close the drain valve.  
Point the spray gun into a waste receptacle and trigger the gun.

#### ■ ADJUSTMENTS

Adjust the "MOTOR AIR" pneumatic regulator to obtain the required pressure and fluid flow (maximum stroke : from 10 to 15 cycles/mn).

If the fluid runs over the drum around the plate seal, unscrew the "CYLINDER AIR" regulator to decrease the pressure.

If the pump races, it is because it does not exhaust material. Screw the "CYLINDER AIR" regulator to increase the plate thrust

Between the pump fluid outlet and the gun fluid inlet, you can fit a pressure regulator to control and adjust the gun fluid pressure.

#### ■ PUMPS IN PAIRS

Prime each pump. Place the installation in automatic mode. One of the pump will operate, the other one will be waiting.

When the first drum will be empty, the first pump will stop; the second one will be in automatic mode to prevent from any fluid interruption into the circuit.

#### ■ FILLING GROUP FOR HOT EXTRUSION

Before priming the pumps, put the bay or the electric box that pilots the stoking into service.

Program the temperature regulators (instruction temperature, maximum and minimum alarms).

Put the different components of the installation that must be heated on to heat.

Prime each pump when the instruction temperature is reached.

#### ■ SHUTDOWN AT THE END OF THE WORK

**Guards (motor cover, coupling shields, connectors,...) have been designed for a safe use of the equipment.**

**The manufacturer will not be held responsible for bodily injury or failure and / or property damage due to destruction, the overshadowing or the partial or total removal of the guards.**

Unscrew the air regulator (s).

Leave the pump full of material.

If the pump is equipped with a follower plate, the follower plate must be in contact with the fluid to behave as a cover and prevent from the material drying.

When stopping the pump for a long time, after flushing it, leave it filled with solvent.

## 7. MAINTENANCE

**Guards (motor cover, coupling shields, connectors,...) have been designed for a safe use of the equipment.**

**The manufacturer will not be held responsible for bodily injury or failure and / or property damage due to destruction, the overshadowing or the partial or total removal of the guards.**

### ■ DAILY CARE

Respect the safety instructions (shut off the air and depressurize the circuits before any intervention on the installation).

Check if there are leaks. Check that the hoses are in good condition.

Keep the piston of the pumps clean to prevent from material drying.

Check the lubricant level on the upper cup of the pump. Fill it if necessary. The lubricant will normally be coloured by the material.

If the pump is fitted with a follower plate : check that the plate seal is in good condition, clean top and bottom parts of the follower plate.

Manipulate (open and close) all the valves of the installation.

Keep the spray area clean.

### ■ BIMONTHLY CARE

Check that there is no leak at the upper cartridge.

If the lubricant is excessively coloured in the cup, fill the cup with new lubricant. Leave the cup clean and clean it regularly with lubricant after having drained the lubricant.

Change the seals of the upper flange if necessary.

### ■ MONTHLY CARE

Check and tighten the upper cartridge (shut off pump and disconnect air on the motor).

Check and tighten coupling parts.

(The linear speed of the pump must be the same during the up and down strokes).

### ■ YEARLY CARE

Disassemble the pumps : replace the packings and seals.

## 8. TROUBLESHOOTING CHART

TROUBLE	CAUSE	SOLUTION
<b>Pump does not start or stops.</b>	Air supply. Packings of fluid section piston are stuck. Frosting (motor). Nozzle is clogged.	Check air pressure. Clean or replace. Defrost and lubricate using oil. Clean it.
<b>The pump cycles continuously (drain valve closed).</b>	No starting up. Lack of material. Valve is blocked.	Check feeding pressure. Clean or replace.
<b>The pump piston goes down faster than it goes up.</b>	Leakage from the suction valve.	Clean it.
<b>The pump piston goes up faster than it goes down.</b>	Leakage from the exhaust valve.	Clean it.
<b>The pump goes down rapidly half way, then resumes normal speed.</b>	Pump improperly drained. Leakage from the suction valve.	Open the drain valve until material starts coming out regularly. Then, close the drain valve. Check suction valve.
<b>The pump operates but provides an irregular flow rate.</b>	Air in the chamber. Bad tightness of the valves.	Check the fittings. Clean them.
<b>The pump does not reverse.</b>	Check the spring of the motor reversing block. Check if there is piloting air.	Lubricate the reversing with HP 150 oil. Increase pressure.